

---

**NFPA 14**  
**Standard for the Installation of Standpipe, Private Hydrant, and Hose**  
**Systems**  
**2000 Edition**

---

Copyright © 2000 NFPA, All Rights Reserved

This edition of NFPA 14, *Standard for the Installation of Standpipe, Private Hydrant, and Hose Systems*, was prepared by the Technical Committee on Standpipes and acted on by the National Fire Protection Association, Inc., at its November Meeting held November 14-17, 1999, in New Orleans, LA. It was issued by the Standards Council on January 14, 2000, with an effective date of February 11, 2000, and supersedes all previous editions.

This edition of NFPA 14 was approved as an American National Standard on February 11, 2000.

#### **Origin and Development of NFPA 14**

This standard dates from 1912, when an initial report was made by the Committee on Standpipe and Hose Systems. The report was amended in 1914 and adopted by the Association in 1915. Revisions were adopted in 1917. Additional revisions were submitted by the Committee on Field Practice and adopted in 1926, 1927, 1931, 1938 (included action by the NFPA Board of Directors), 1941, and 1945. The Committee on Standpipes recommended revisions adopted in 1949, 1952, 1963, 1968, 1969, 1970, 1971, 1973, 1974, 1976, 1978, 1980, 1982, 1985, and 1990.

The 1993 edition of NFPA 14 was a complete reorganization of the document. The “user friendliness” of NFPA 14 was evaluated, and numerous changes followed. The standard was arranged to provide for a logical system design approach where designing and installing a standpipe system.

Substantive changes to the 1993 edition were the result of recent experience with standpipe systems under fire conditions. Flow rates, pressures, and the specific location of the hose connections were studied to determine optimum combinations for each factor.

The 1996 edition of NFPA 14 was a continuation of the changes that were initiated for the 1993 edition. Some definitions were expanded, and certain requirements for piping materials, pipe support, waterflow alarms, valves, fire department connections, system testing, and water supplies were revised. In addition, a number of editorial changes were made to improve the user friendliness of the document.

The 2000 edition of NFPA 14 incorporates requirements for hydrants, hose houses, and master streams previously contained in NFPA 24. Also included in this revision are test procedures for fire flow testing and marking of hydrants previously contained in NFPA 291.

#### **Technical Committee on Standpipes**

**Maurice M. Pilette, Chair**  
Mechanical Designs Ltd, MA [SE]

**Gary S. Address**, Wausau HPR Engr, WI [I]

Rep. The Alliance of American Insurers

**Willis C. Beard**, Fire Equipment Co. Inc., MI [M]

Rep. Nat'l Assn. of Fire Equipment Distributors Inc.

**Richard W. Bonds**, Ductile Iron Pipe Research Assn., AL [M]

**Antonio C. M. Braga**, Factory Mutual Research Corp., CA [I]

**Thomas C. Brown**, Rolf Jensen & Assoc., Inc., VA [SE]

**Larry Buckett**, Vipond Fire Protection, Canada [IM]

Rep. Canadian Automatic Sprinkler Assn.

**Roger L. Chamberland**, City of Winnipeg Fire Dept., Canada [E]

**Thomas H. Dale**, Kemper Nat'l Insurance Cos., PA [I]

**Walter A. Damon**, Schirmer Engr Corp., IL [SE]

**Gary S. Jensen**, American Emergency Services Corp., IL [U]

**Edwin A. Kotak, Jr.**, Robert W. Sullivan, Inc., MA [SE]

**George E. Laverick**, Underwriters Laboratories Inc., IL [RT]

**John C. Livingston, Jr.**, Livingston Fire Protection, Inc., MD [IM]

**Raymond W. Lonabaugh**, PICO Energy Co., PA [U]

Rep. Edison Electric Inst.

**Terence A. Manning**, Manning Electrical Systems, Inc., IL [IM]

Rep. Illinois Fire Prevention Assn.

**Ausmus S. Marburger**, Fire Protection Industries, Inc., PA [IM]

Rep. Nat'l Fire Sprinkler Assn.

**Jack A. Medovich**, East Coast Fire Protection, Inc., MD [M]

Rep. American Fire Sprinkler Assn., Inc.

**James W. Naylor**, Westinghouse Savannah River Co., SC [U]

**Douglas F. Nelson**, HSB Industrial Risk Insurers, PA [I]

**J. Brian Nolan**, Nolan Fire Pump System Testing, IL [M]

**Sam (Sat) Salwan**, Environmental Systems Design Inc., IL [SE]

**Jeffrey M. Shapiro**, Int'l Code Consultants, TX [SE]

**Copyright NFPA**

**Bruce W. Silk**, Boca Raton Fire Dept., FL [E]

**Richard H. Solomon**, Fire Protection Engr, IL [SE]

**Jeffrey R. Stump**, CIGNA Loss Control Services, PA [I]  
Rep. American Insurance Services Group

**James M. Trapp**, Elkhart Brass Mfr. Co., IN [M]  
Rep. Fire Equipment Mfrs. Assn.

**James B. Visger**, Road Sprinkler Fitters Union, AZ [L]  
Rep. United Assn. of Journeymen and Apprentices of the Plumbing and Pipe Fitting Industry of the U.S. and  
Canada

### **Alternates**

**Tariq Bsharat**, Nat'l Fire Sprinkler Assn., NY [IM]  
(Alt. to A. S. Marburger)

**Lee J. Dosedlo**, Underwriters Laboratories Inc., IL [RT]  
(Alt. to G. E. Laverick)

**John Galt**, Canadian Automatic Sprinkler Assn., Canada [IM]  
(Alt. to L. Buckett)

**Joseph B. Hankins, Jr.**, Factory Mutual Research Corp., MA [I]  
(Alt. to A. C. M. Braga)

**Merle H. Hittle, Jr.**, Schirmer Engr Corp., TX [SE]  
(Alt. to W. A. Damon)

**Kenneth W. Linder**, HSB Industrial Risk Insurers, CT [I]  
(Alt. to D. F. Nelson)

**E. Alan Reilly**, Potter-Roemer Inc., CA [M]  
(Alt. to J. M. Trapp)

**Brach Schmidt**, CIGNA Loss Control Services, OH [I]  
(Alt. to J. R. Stump)

### **Nonvoting**

**Kenneth J. Carl**, Baldwin, NY  
(Member Emeritus)

**James W. Nolan**, James W. Nolan Co., IL  
(Member Emeritus)

**David R. Hague**,  
Copyright NFPA

This list represents the membership at the time the Committee was balloted on the final text of this edition. Since that time, changes in the membership may have occurred. A key to classifications is found at the back of the document.

NOTE: Membership on a committee shall not in and of itself constitute an endorsement of the Association or any document developed by the committee on which the member serves.

**Committee Scope:** This Committee shall have primary responsibility for documents on the installation of standpipe, private hydrant, and hose systems in buildings and structures.

## NFPA 14

### Standard for the Installation of Standpipe, Private Hydrant, and Hose Systems

2000 Edition

NOTICE: An asterisk (\*) following the number or letter designating a paragraph indicates that explanatory material on the paragraph can be found in Appendix A.

Information on referenced publications can be found in Chapter 11 and Appendix C.

## Chapter 1 General Information

### 1-1\* Scope.

This standard covers the minimum requirements for the installation of standpipes, private hydrants, monitor nozzles, hose systems, and hose houses including methods and procedures of waterflow testing for the evaluation of water supplies. This standard does not cover requirements for periodic inspection, testing, and maintenance of these systems.

### 1-2 Purpose.

The purpose of this standard is to provide a reasonable degree of protection for life and property from fire through installation requirements for standpipes, hydrants, and hose systems based on sound engineering principles, test data, and field experience. Nothing in this standard is intended to restrict new technologies or alternate arrangements, provided that the level of safety prescribed by the standard is not lowered.

### 1-3 Retroactivity.

The provisions of this document shall be considered necessary to provide a reasonable level of protection from loss of life and property from fire. They reflect situations and the state of the art at the time the standard was issued.

Unless otherwise noted, it is not intended that the provisions of this document be applied to facilities, equipment, structures, or installations that were existing or approved for construction or installation prior to the effective date of the document.

*Exception: This standard shall apply to those cases where it is determined by the authority having jurisdiction that the existing situation involves a distinct hazard to life or property.*

### 1-4 Definitions.

**1-4.1\* Approved.** Acceptable to the authority having jurisdiction.

**1-4.2\* Authority Having Jurisdiction.** The organization, office, or individual responsible for approving equipment, materials, an installation, or a procedure.

**1-4.3 Automatic Standpipe System.** A standpipe system that is attached to a water supply capable of supplying the system demand at all times and that requires no action other than opening a hose valve to provide water at hose connections. *(See Chapter 3.)*

**1-4.4 Branch Line.** A piping system, generally in a horizontal plane, connecting one or more hose connections with a standpipe.

**1-4.5 Combined System.** A standpipe system having piping that supplies both hose connections and automatic sprinklers.

**1-4.6 Control Valve.** A valve used to control the water supply system of a standpipe system.

**1-4.7 Dry Standpipe.** A standpipe system designed to have piping contain water only when the system is being utilized. *(See Chapter 3.)*

**1-4.8 Feed Main.** That portion of a standpipe system that supplies water to one or more standpipes.

**1-4.9 Fire Department Connection.** A connection through which the fire department can pump supplemental water into the sprinkler system, standpipe, or other system furnishing water for fire extinguishment to supplemental existing water supplies.

**1-4.10 High-Rise Building.** A building more than 75 ft (23 m) in height. Building height shall be measured from the lowest level of fire department vehicle access to the floor of the highest occupiable story.

**1-4.11 Hose Connection.** A combination of equipment provided for connection of a hose to the standpipe system that includes a hose valve with a threaded outlet.

**1-4.12 Hose Station.** A combination of a hose rack, hose nozzle, hose, and hose connection.

**1-4.13 Hose Valve.** The valve to an individual hose connection.

**1-4.14\* Listed.** Equipment, materials, or services included in a list published by an organization that is acceptable to the authority having jurisdiction and concerned with evaluation of products or services, that maintains periodic inspection of production of listed equipment or materials or periodic evaluation of services, and whose listing states that either the equipment, material, or service meets appropriate designated standards or has been tested and found suitable for a specified purpose.

**1-4.15 Manual Standpipe System.** A standpipe system that relies exclusively on the fire department connection to supply the system demand. *(See Chapter 3.)*

**1-4.16 Pressure, Nozzle.** Pressure required at the inlet of a nozzle to produce the desired water discharge characteristics.

**1-4.17 Pressure, Residual.** Pressure acting on a point in the system with a flow being delivered.

**1-4.18 Pressure, Static.** Pressure acting on a point in the system with no flow from the system.

**1-4.19 Pressure Control Valve.** A pilot-operated pressure-reducing valve designed for the purpose of reducing the downstream water pressure to a specific value under both flowing (residual) and nonflowing (static) conditions.

**1-4.20\* Pressure-Reducing Valve.** A valve designed for the purpose of reducing the downstream water pressure under both flowing (residual) and nonflowing (static) conditions.

**1-4.21 Pressure-Regulating Device.** A device designed for the purpose of reducing, regulating, controlling, or restricting water pressure. Examples include pressure-reducing valves, pressure control valves, and pressure-restricting devices.

**1-4.22 Pressure-Restricting Device.** A valve or device designed for the purpose of reducing the downstream

water pressure under flowing (residual) conditions only.

**1-4.23 Rated Capacity.** The flow available from a device, at the designated residual pressure either measured or calculated.

**1-4.24 Semiautomatic Standpipe System.** A standpipe system that is attached to a water supply capable of supplying the system demand at all times and that requires activation of a control device to provide water at hose connections. (See Chapter 3.)

**1-4.25 Shall.** Indicates a mandatory requirement.

**1-4.26 Should.** Indicates a recommendation or that which is advised but not required.

**1-4.27 Standpipe.** The riser portion of the system piping that delivers the water supply for hose connections, and sprinklers on combined systems, vertically from floor to floor.

**1-4.28 Standpipe System.** An arrangement of piping, valves, hose connections, and allied equipment installed in a building or structure, with the hose connections located in such a manner that water can be discharged in streams or spray patterns through attached hose and nozzles, for the purpose of extinguishing a fire, thereby protecting a building or structure and its contents in addition to protecting the occupants. This is accomplished by means of connections to water supply systems or by means of pumps, tanks, and other equipment necessary to provide an adequate supply of water to the hose connections.

**1-4.29 Standpipe System Zone.** A vertical subdivision of a standpipe system by height.

**1-4.30 System Demand.** The flow rate and residual pressure required from a water supply, measured at the point of connection of a water supply to a standpipe system, to deliver the total waterflow rate required for a standpipe system established in Section 5-9, the minimum residual pressures established by Section 5-7 at the hydraulically most remote hose, and the minimum waterflow rate for sprinkler connections, on combined systems.

**1-4.31 Type (of System).** See Chapter 3.

**1-4.32 Wet Standpipe.** A standpipe system having piping containing water at all times. (See Chapter 3.)

## 1-5 Units.

### 1-5.1

Metric units of measurement in this standard are in accordance with the modernized metric system known as the International System of Units (SI). Liter and bar units, which are outside of but recognized by SI, are commonly used in international fire protection. These units and their conversion factors are provided in Table 1-5.1.

**Table 1-5.1 Metric Units of Measure**

Name of Unit	Unit Symbol	Conversion Factor
meter	m	1 ft = 0.3048 m
millimeter	mm	1 in. = 25.4 mm
liter	L	1 gal = 3.785 L
cubic decimeter	dm <sup>3</sup>	1 gal = 3.785 dm <sup>3</sup>
Pascal	Pa	1 psi = 6894.757 Pa
bar	bar	1 psi = 0.0689 bar
bar	bar	1 bar = 10 <sup>5</sup> Pa

Note: For additional conversion and information, see ASTM E 380, *Standard Practice for Use of the International System of Units (SI)*.

### 1-5.2

If a value for measurement provided in this standard is followed by an equivalent value in other units, the first value stated shall be regarded as the requirement. An equivalent value could be approximate.

## Chapter 2 System Components and Hardware

### 2-1\* General.

Standpipe system components and hardware shall be in accordance with this chapter. All devices and materials used in standpipe systems shall be of an approved type. System components shall be rated for working pressures not less than the maximum pressure to be developed at their corresponding locations within the system under any condition, including the pressure that occurs when a permanently installed fire pump is operating at shutoff pressure.

### 2-2 Pipe and Tube.

#### 2-2.1

Pipe or tube used in standpipe systems shall meet or exceed one of the standards in Table 2-2.1 or shall be in accordance with 2-2.2 through 2-2.6.

**Table 2-2.1 Pipe or Tube Materials and Dimensions**

Material and Dimensions (Specifications)	Standard
<b>Ferrous Piping</b>	
<i>Ductile-Iron Pipe, Centrifugally Cast, for Water or Other Liquids</i>	AWWA C151
<b>Electric-Resistance Welded Steel Pipe</b>	
<i>Standard Specification for Electric-Resistance-Welded Steel Pipe</i>	ASTM A 135
<b>Welded and Seamless Steel</b>	
<i>Standard Specification for Black and Hot-Dipped Zinc-Coated (Galvanized) Welded and Seamless Steel Pipe for Fire Protection Use</i>	ASTM A 795
<b>Welded and Seamless Steel Pipe</b>	
<i>Standard Specification for Pipe, Steel, Black and Hot-Dipped, Zinc-Coated, Welded and Seamless</i>	ASTM A 53
<i>Welded and Seamless Wrought Steel Pipe</i>	ANSI B36.10M
<b>Copper Tube (Drawn, Seamless)</b>	
<i>Standard Specification for Seamless Copper Tube</i>	ASTM B 75
<i>Standard Specification for Seamless Copper Water Tube</i>	ASTM B 88
<i>Standard Specification for General Requirements for Wrought Seamless Copper and Copper-Alloy Tube</i>	ASTM B 251
<b>Brazing Filler Metal (Classifications BCuP-3 or BCuP-4)</b>	
<i>Specification for Filler Metals for Brazing and Braze Welding</i>	AWS A5.8

#### 2-2.2

Where ductile iron pipe is installed in accordance with Table 2-2.1, it shall be lined in accordance with AWWA C104, *Cement-Mortar Lining for Ductile-Iron Pipe and Fittings for Water*.

### **2-2.3**

Where steel pipe specified in Table 2-2.1 is used and joined by welding as specified in Section 2-4 or by roll-grooved pipe and fittings as specified in Section 2-4, the minimum nominal wall thickness for pressures up to 300 psi (20.7 bar) shall be in accordance with Schedule 10 for pipe sizes up to 5 in. (127 mm), 0.134 in. (3.40 mm) for 6-in. (152-mm) pipe, and 0.188 in. (4.78 mm) for 8-in. and 10-in. (203-mm and 254-mm) pipe.

*Exception: Pressure limitations and wall thickness for steel pipe listed in accordance with 2-2.6 shall be in accordance with the listing requirements.*

### **2-2.4**

Where steel pipe specified in Table 2-2.1 is joined by threaded fittings as specified in Section 2-4 or by fittings used with pipe having cut grooves, the minimum wall thickness shall be in accordance with Schedule 30 [sizes 8 in. (203 mm) and larger] or Schedule 40 [sizes less than 8 in. (203 mm)] pipe for pressures up to 300 psi (20.7 bar).

*Exception: Pressure limitations and wall thicknesses for steel pipe specially listed in accordance with 2-2.6 shall be in accordance with the listing requirements.*

### **2-2.5**

Copper tube as specified in the standards referenced in Table 2-2.1 shall have a wall thickness of Type K, L, or M where used in standpipe systems.

### **2-2.6**

Other types of pipe or tube investigated for suitability in standpipe installations and listed for this service, including, but not limited to, steel differing from that provided in Table 2-2.1, shall be permitted where installed in accordance with their listing limitations, including installation instructions. Pipe or tube shall not be listed for portions of an occupancy classification.

### **2-2.7**

Bending of Schedule 40 steel pipe and Types K and L copper tube shall be permitted where bends are made with no kinks, ripples, distortions, reductions in diameter, or any noticeable deviations from a round shape. The minimum radius of a bend shall be six pipe diameters for pipe sizes 2 in. (51 mm) and smaller, and five pipe diameters for pipe sizes 2½ in. (64 mm) and larger.

## **2-3 Fittings.**

### **2-3.1**

Fittings used in standpipe systems shall meet or exceed the standards in Table 2-3.1 or shall be in accordance with 2-3.2.

### **2-3.2**

Other types of fittings investigated for suitability in standpipe installations and listed for this service, including, but not limited to, steel differing from that provided in Table 2-3.1, shall be permitted where installed in accordance with their listing limitations, including installation instructions.

### **2-3.3**

Fittings shall be extra-heavy pattern where pressures exceed 175 psi (12.1 bar).

*Exception No. 1: Standard weight pattern cast-iron fittings 2 in. (51 mm) in size and smaller shall be permitted where pressures do not exceed 300 psi (20.7 bar).*



*Exception No. 2: Standard weight pattern malleable-iron fittings 6 in. (152 mm) in size and smaller shall be permitted where pressures do not exceed 300 psi (20.7 bar).*

*Exception No. 3: Fittings shall be permitted for system pressures up to the limits specified in their listings.*

### **2-3.4**

Screwed unions shall not be used on pipe larger than 2 in. (51 mm). Couplings and unions of other than the screwed type shall be of the types listed specifically for use in standpipe systems.

### **2-3.5**

A one-piece reducing fitting shall be used wherever a change is made in the size of the pipe.

*Exception: Hexagonal or face bushings shall be permitted for reducing the size of openings of fittings where standard fittings of the required size are not available.*

**Table 2-3.1 Fittings Materials and Dimensions**

<b>Materials and Dimensions</b>	<b>Standard</b>
<b>Cast Iron</b>	
<i>Gray Iron Threaded Fittings</i>	ANSI B16.4
<i>Cast Iron Pipe Flanges and Flanged Fittings</i>	ANSI B16.1
<b>Malleable Iron</b>	
<i>Malleable Iron Threaded Fittings</i>	ANSI B16.3
<b>Ductile Iron</b>	
<i>Ductile-Iron Fittings and Gray-Iron Fittings, 3 in. Through 48 in. (75 mm Through 1200 mm) for Water and Other Liquids</i>	AWWA C110
<b>Steel</b>	
<i>Factory-Made Wrought Steel Buttwelding Fittings</i>	ANSI B16.9
<i>Buttwelding End</i>	ANSI B16.25
<i>Standard Specification for Piping Fittings of Wrought Carbon Steel and Alloy Steel for Moderate and Elevated Temperatures</i>	ASTM A 234
<i>Pipe Flanges and Flanged Fittings</i>	ANSI B16.5
<i>Forged Fittings, Socket-Welding and Threaded</i>	ANSI B16.11
<b>Copper</b>	
<i>Wrought Copper and Copper Alloy Solder Joint Pressure Fittings</i>	ANSI B16.22
<i>Cast Copper Alloy Solder Joint Pressure Fittings</i>	ANSI B16.18

### **2-4 Joining of Pipe and Fittings.**

Joining, hanging, and bracing of pipe and fittings shall be in accordance with NFPA 13, *Standard for the Installation of Sprinkler Systems*.

### **2-5 Valves.**

All valves controlling connections to water supplies and standpipes shall be listed indicating valves.

Such valves shall not close in less than 5 seconds when operated at maximum possible speed from the fully open position.

*Exception No. 1: A listed underground gate valve equipped with a listed indicator post shall be permitted.*

*Exception No. 2: A listed water control valve assembly with a reliable position indication connected to a remote supervisory station shall be permitted.*

*Exception No. 3: A nonindicating valve, such as an underground gate valve with approved roadway box complete with T-wrench, acceptable to the authority having jurisdiction, shall be permitted.*

## **2-6 Hose Stations.**

### **2-6.1 Closets and Cabinets.**

#### **2-6.1.1**

Closets and cabinets used to contain fire hose shall be of a sufficient size to allow the installation of the necessary equipment at hose stations and designed so they do not interfere with the prompt use of the hose connection, the hose, and other equipment at the time of fire. Within the cabinet, the hose connections shall be located so that there is at least 1 in. (25.4 mm) between any part of the cabinet and the handle of the valve when the valve is in any position ranging from fully open to fully closed. The cabinet shall be used for fire equipment only, and each cabinet shall be conspicuously identified.

#### **2-6.1.2**

Where a “break glass”-type protective cover for a latching device is provided, the device provided to break the glass panel shall be attached securely in the immediate area of the break glass panel and shall be arranged so that the device cannot be used to break other glass panels in the cabinet door.

#### **2-6.1.3**

Where a fire-resistive assembly is penetrated by a cabinet, the fire resistance of the assembly shall be maintained as required by the local building code.

### **2-6.2 Hose Houses and Equipment.**

#### **2-6.2.1\***

A supply of hose and equipment shall be provided when hydrants are intended for use by plant personnel or a fire brigade. The quantity and type of hose and equipment will depend upon the number and location of hydrants relative to the protected property, the extent of the hazard, and the fire-fighting capabilities of the potential users. The authority having jurisdiction shall be consulted.

#### **2-6.2.2\***

Hose shall be stored so it is readily accessible and is protected from the weather.

#### **2-6.2.3**

Hose houses shall be of substantial construction on foundations. The construction shall be such as to protect the hose from weather and vermin, and designed so that hose lines can be brought into use. Clearance shall be provided for operation of the hydrant wrench. Ventilation shall be provided. The exterior shall be painted or otherwise suitably protected against deterioration.

#### **2-6.2.4\***

Hose houses shall be of a size and arrangement to provide shelves or racks for the hose and equipment. (*For equipment details of hose houses, see 2-6.2.6.*)

#### **2-6.2.5**

Hose houses shall be plainly identified.

## **2-6.2.6 General Equipment.**

### **2-6.2.6.1\***

When hose houses are used in addition to the hose, each shall be equipped with the following:

- (1) Two approved adjustable spray-solid stream nozzles equipped with shutoffs for each size of hose provided
- (2) One hydrant wrench (in addition to wrench on hydrant)
- (3) Four coupling spanners for each size hose provided
- (4) Two hose coupling gaskets for each size hose

### **2-6.2.6.2**

Where two sizes of hose and nozzles are provided, reducers or gated wyes shall be included in the hose house equipment.

### **2-6.2.7**

The use of hydrants and hose for purposes other than fire-related services shall be prohibited.

## **2-6.3 Hose.**

Each hose connection provided for use by building occupants (Class II and Class III systems) shall be equipped with not more than 100 ft (30.5 m) of listed, 1½-in. (38.1-mm), lined, collapsible or noncollapsible fire hose attached and ready for use.

*Exception: Where hose less than 1½ in. (38.1 mm) is used for 1½-in. (38.1-mm) hose stations in accordance with 3-3.2 and 3-3.3, listed noncollapsible hose shall be used.*

## **2-6.4 Hose Racks.**

Each 1½-in. (38.1-mm) hose station provided with 1½-in. (38.1-mm) hose shall be equipped with a listed rack or other approved storage facility.

Each 1½-in. (38.1-mm) hose station provided with hose less than 1½ in. (38.1 mm) in accordance with 3-3.2 and 3-3.3 shall be equipped with a listed continuous flow reel.

## **2-6.5 Nozzles.**

Nozzles provided for Class II service shall be listed.

## **2-6.6 Label.**

Each rack or storage facility for 1½-in. (38.1-mm) or smaller hose shall be provided with a label that includes the wording “fire hose for use by occupants” and operating instructions.

## **2-7 Hose Connections.**

Hose connections shall have external National Hose Standard (NHS) threads, for the valve size specified, in accordance with NFPA 1963, *Standard for Fire Hose Connections*. Hose connections shall be equipped with caps to protect the hose threads.

*Exception: Where local fire department hose threads do not conform to NFPA 1963, the authority having jurisdiction shall designate the hose threads that shall be used.*

## **2-8\* Fire Department Connections.**

### **2-8.1**

Fire department connections shall be listed for a working pressure equal to or greater than the pressure requirement

of the system demand.

## **2-8.2\***

Each fire department connection shall have at least two 2<sup>1</sup>/<sub>2</sub>-in. (63.5-mm) internal threaded swivel fittings having NHS threads, as specified in NFPA 1963, *Standard for Fire Hose Connections*. Fire department connections shall be equipped with caps to protect the system from the entry of debris.

*Exception: Where the local fire department uses fittings that differ from those specified, fittings compatible with local fire department equipment shall be used and their minimum size shall be 2<sup>1</sup>/<sub>2</sub> in. (62 mm).*

## **2-9\* General.**

### **2-9.1**

Hydrants shall be of approved type and have not less than a 6-in. (152-mm) diameter connection with the mains. A valve shall be installed in the hydrant connection. The number, size, and arrangement of outlets, the size of the main valve opening, and the size of the barrel shall be suitable for the protection to be provided and shall be approved by the authority having jurisdiction. Independent gate valves on 2<sup>1</sup>/<sub>2</sub>-in. (64-mm) outlets are permitted. (*See Section 2-6.*)

### **2-9.2\***

Hydrant outlet threads shall have the NHS external threads for the size outlet(s) supplied as specified in NFPA 1963, *Standard for Fire Hose Connections*.

*Exception: Where local fire department connections do not conform to NFPA 1963, the authority having jurisdiction shall designate the connection to be used.*

### **2-9.3\***

Hydrants on private service mains shall not be equipped with pumper outlets unless the calculated demand for large hose (3.5 in. and larger) is added to the attack hose and sprinkler system demands in determining the total demand on the fire protection water supply.

## **2-10 Signs.**

Signs shall be permanently marked and shall be constructed of weather-resistant metal or rigid plastic materials.

# **Chapter 3 System Requirements**

## **3-1 General.**

### **3-1.1**

The number and arrangement of standpipe equipment necessary for proper protection is governed by local conditions such as the occupancy, character, and construction of the building and its accessibility. The authority having jurisdiction shall be consulted regarding the required type of system, class of system, and special requirements.

### **3-1.2**

The spacing and location of standpipes and hose connections shall be in accordance with Chapter 5.

### **3-1.3**

Standpipe and hose systems not required by the authority having jurisdiction and not meeting the requirements of this standard shall be marked with a sign that reads "FOR FIRE BRIGADE USE ONLY."

## **3-2 Types of Standpipe Systems.**

### **3-2.1 Automatic-Dry.**

An automatic-dry standpipe system shall be a dry standpipe system, normally filled with pressurized air, that is arranged through the use of a device, such as a dry pipe valve, to admit water into the system piping automatically upon the opening of a hose valve. The water supply for an automatic-dry standpipe system shall be capable of supplying the system demand.

#### **3-2.1.1\* Permanently Inoperative Hydrants.**

Fire hydrants that are permanently inoperative or unusable should have barrels, nozzle caps, tops, and all visible parts painted black.

#### **3-2.1.2\* Temporarily Inoperative Hydrants.**

Fire hydrants that are temporarily inoperative or unusable should be wrapped or otherwise provided with temporary indication of their condition.

### **3-2.2 Automatic-Wet.**

An automatic-wet standpipe system shall be a wet standpipe system that has a water supply that is capable of supplying the system demand automatically.

### **3-2.3 Semiautomatic-Dry.**

A semiautomatic-dry standpipe system shall be a dry standpipe system that is arranged through the use of a device, such as a deluge valve, to admit water into the system piping upon activation of a remote control device located at a hose connection. A remote control activation device shall be provided at each hose connection. The water supply for a semiautomatic-dry standpipe system shall be capable of supplying the system demand.

### **3-2.4 Manual-Dry.**

A manual-dry standpipe system shall be a dry standpipe system that does not have a permanent water supply attached to the system. Manual-dry standpipe systems need water from a fire department pumper (or the like) to be pumped into the system through the fire department connection in order to supply the system demand.

### **3-2.5 Manual-Wet.**

A manual-wet standpipe system shall be a wet standpipe system connected to a small water supply for the purpose of maintaining water within the system but does not have a water supply capable of delivering the system demand attached to the system. Manual-wet standpipe systems need water from a fire department pumper (or the like) to be pumped into the system in order to supply the system demand.

## **3-3 Classes of Standpipe Systems.**

### **3-3.1 Class I Systems.**

A Class I standpipe system shall provide 2½-in. (63.5-mm) hose connections to supply water for use by fire departments and those trained in handling heavy fire streams.

### **3-3.2 Class II Systems.**

A Class II standpipe system shall provide 1½-in. (38.1-mm) hose stations to supply water for use primarily by the building occupants or by the fire department during initial response.

*Exception: A minimum 1-in. (25.4-mm) hose shall be permitted to be used for hose stations in light hazard occupancies where investigated and listed for this service and where approved by the authority having jurisdiction.*

### **3-3.3 Class III Systems.**

A Class III standpipe system shall provide 1½-in. (38.1-mm) hose stations to supply water for use by building occupants and 2½-in. (63.5-mm) hose connections to supply a larger volume of water for use by fire departments and those trained in handling heavy fire streams.

*Exception No. 1: A minimum 1-in. (25.4-mm) hose shall be permitted to be used for hose stations in light hazard occupancies where investigated and listed for this service and where approved by the authority having jurisdiction.*

*Exception No. 2: Where the building is protected throughout by an approved automatic sprinkler system, hose stations for use by the building occupants shall not be required, subject to the approval of the authority having jurisdiction, provided that each hose connection is 2½ in. (63.5 mm) and is equipped with a 2½-in. 1½-in. (63.5-mm 38.2-mm) reducer and a cap attached with a chain.*

### **3-4 Requirements for Manual Standpipe Systems.**

#### **3-4.1**

Manual standpipe systems shall not be used in high-rise buildings.

#### **3-4.2**

Each hose connection for manual standpipes shall be provided with a conspicuous sign that reads “MANUAL STANDPIPE FOR FIRE DEPARTMENT USE ONLY.”

#### **3-4.3**

Manual standpipes shall not be used for Class II or Class III systems.

### **3-5 Requirements for Dry Standpipe Systems.**

#### **3-5.1**

Dry standpipes shall be used only where piping is subject to freezing.

#### **3-5.2**

Dry standpipes shall not be used for Class II or Class III systems.

*Exception: In facilities where fire brigades are trained to operate systems without fire department intervention.*

### **3-6\* Gauges.**

#### **3-6.1**

A listed 3½-in. (89-mm) dial spring pressure gauge shall be connected to each discharge pipe from the fire pump and the public waterworks at the pressure tank, at the air pump supplying the pressure tank, and at the top of each standpipe. Gauges shall be located in a suitable place so that water cannot freeze. Each gauge shall be controlled by a valve having an arrangement for draining.

*Exception: Where several standpipes are interconnected at the top, a single gauge, properly located, shall be permitted to be substituted for a gauge at the top of each standpipe.*

#### **3-6.2**

A valved outlet for a pressure gauge shall be installed on the upstream side of every pressure-regulating device.

### **3-7\* Waterflow Alarms.**

#### **3-7.1**

Where required by the authority having jurisdiction for automatic or semiautomatic systems, listed waterflow alarms shall be provided.

### **3-7.2**

Waterflow alarms shall utilize a sensing mechanism appropriate to the type of standpipe.

### **3-7.3**

Paddle-type waterflow alarms shall be used on wet standpipe systems only.

## **Chapter 4 Installation Requirements**

### **4-1\* Location and Protection of Piping.**

#### **4-1.1 Location of Dry Standpipes.**

Dry standpipes shall not be concealed in building walls or built into pilasters.

#### **4-1.2 Protection of Piping.**

##### **4-1.2.1\***

Standpipe system piping shall not pass through hazardous areas and shall be located so that it is protected from mechanical and fire damage.

##### **4-1.2.2**

Standpipes and lateral piping supplied by standpipes shall be located in enclosed exit stairways or shall be protected by a degree of fire resistance equal to that required for enclosed exit stairways in the building in which they are located.

*Exception No. 1: In buildings equipped with an approved automatic sprinkler system, lateral piping to 2½-in. (63.5-mm) hose connections shall not be required to be protected.*

*Exception No. 2: Piping connecting standpipes to 1½-in. (38.1-mm) hose connections.*

##### **4-1.2.3**

Where a standpipe or lateral pipe that is normally filled with water passes through an area subject to freezing temperatures, it shall be protected by a reliable means to maintain the temperature of the water in the piping between 40°F and 120°F (4.4°C and 48.9°C).

Antifreeze solutions shall not be used to protect standpipe system piping from freezing.

##### **4-1.2.4**

Where corrosive conditions exist or piping is exposed to the weather, corrosion-resistant types of pipe, tube, fittings, and hangers or protective corrosion-resistive coatings shall be used. If steel pipe is to be buried underground, it shall be protected against corrosion before being buried.

##### **4-1.2.5**

To minimize or prevent pipe breakage where subject to earthquakes, standpipe systems shall be protected in accordance with NFPA 13, *Standard for the Installation of Sprinkler Systems*.

##### **4-1.2.6**

Piping for any standpipe system shall be permitted to be installed underground. Pipe shall not be run under buildings.

*Exception: When absolutely necessary to run pipe under buildings, special precautions shall be taken that*

*include arching the foundation walls over the pipe, running pipe in covered trenches, and providing valves to isolate sections of pipe under buildings.*

## **4-2 Gate Valves and Check Valves.**

### **4-2.1**

Connections to each water supply shall be provided with an approved indicating-type valve and check valve located close to the supply, such as at tanks, pumps, and connections from waterworks systems.

*Exception: Fire department connections.*

### **4-2.2**

Valves shall be provided to allow isolation of a standpipe without interrupting the supply to other standpipes from the same source of supply.

### **4-2.3**

Listed indicating-type valves shall be provided at the standpipe for controlling branch lines for remote hose stations.

### **4-2.4**

Where wafer-type valve discs are used, they shall be installed so that they do not interfere with the operation of other system components.

## **4-2.5 Valves on Combined Systems.**

### **4-2.5.1**

Each connection from a standpipe that is part of a combined system to a sprinkler system shall have an individual control valve of the same size as the connection.

### **4-2.5.2\***

Each connection from a standpipe that is part of a combined system to a sprinkler system and interconnected with other standpipes shall have an individual control valve and check valve of the same size at the connection.

## **4-2.6 Valves on Connections to Water Supplies.**

### **4-2.6.1**

Connections to public water systems shall be controlled by post indicator valves of an approved type located at least 40 ft (12.2 m) from the building protected. All valves shall be plainly marked to indicate the service that they control.

*Exception No. 1: Where the valve cannot be located at least 40 ft (12.2 m) from the building, it shall be installed in an approved location and where it is readily accessible in case of fire and not subject to damage.*

*Exception No. 2: Where post indicator valves cannot be used, underground valves shall be permitted. The valve locations, directions for their opening, and services that they control shall be plainly marked on the buildings served.*

### **4-2.6.2\***

Where the standpipes are supplied from a yard main or header in another building, the connection shall be provided with a listed indicating-type valve located outside at a safe distance from the building or at the header.

## **4-2.7 Valve Supervision.**

System water supply valves, isolation control valves, and other valves in feed mains shall be supervised in an approved manner in the open position by one of the following methods:



- (1) A central station, proprietary, or remote station signaling service
- (2) A local signaling service that initiates an audible signal at a constantly attended location
- (3) Locking of valves in the open position
- (4) Sealing of valves and an approved weekly recorded inspection where valves are located within fenced enclosures under the control of the owner

*Exception: Underground gate valves with roadway boxes shall not be required to be supervised.*

## **4-2.8 Signs and Room Identification for Valves.**

### **4-2.8.1**

All main and sectional system control valves, including water supply control valves, shall have a sign indicating the portion of the system that is controlled by the valve.

### **4-2.8.2**

All control, drain, and test connection valves shall be provided with signs indicating their purpose.

### **4-2.8.3**

Where sprinkler system piping supplied by a combined system is supplied by more than one standpipe (“loop” or “dual feed” design), a sign shall be located at each dual or multiple feed connection to the combination system standpipe to indicate that in order to isolate the sprinkler system served by the control valve, an additional control valve or valves at other standpipes shall be shut off. The sign also shall identify the location of the additional control valves.

### **4-2.8.4**

Where a main or sectional system control valve is located in a closed room or concealed space, the location of the valve shall be indicated by a sign in an approved location on the outside of the door or near the opening to the concealed space.

## **4-3\* Fire Department Connections.**

### **4-3.1**

There shall be no shutoff valve between the fire department connection and the system.

### **4-3.2**

A listed check valve shall be installed in each fire department connection and located as near as practicable to the point where it joins the system.

### **4-3.3**

The fire department connection shall be installed as follows:

- (a) *Automatic-Wet and Manual-Wet Standpipe Systems.* On the system side of the system control valve, check valve, or any pump, but on the supply side of any isolating valves required in 4-2.2.
- (b) *Automatic-Dry Standpipe Systems.* On the system side of the control valve and check valve and the supply side of the dry pipe valve.
- (c) *Semiautomatic-Dry Standpipe Systems.* On the system side of the deluge valve.
- (d) *Manual-Dry Standpipe Systems.* Directly connected to system piping.

### **4-3.4**

In areas subject to freezing, a listed automatic drip valve that is arranged to allow drainage without causing water

damage shall be installed in the piping between the check valve and the fire department connection.

### **4-3.5 Location and Identification.**

#### **4-3.5.1**

Fire department connections shall be on the street side of buildings, fully visible and recognizable from the street or nearest point of fire department apparatus accessibility, and shall be located and arranged so that hose lines can be attached to the inlets without interference from nearby objects, including buildings, fences, posts, or other fire department connections.

#### **4-3.5.2**

Each fire department connection shall be designated by a sign having raised letters, at least 1 in. (25.4 mm) in height, cast on a plate or fitting that reads "STANDPIPE." If automatic sprinklers are also supplied by the fire department connection, the sign or combination of signs shall indicate both designated services (e.g., "STANDPIPE AND AUTOSPKR," or "AUTOSPKR AND STANDPIPE").

A sign also shall indicate the pressure required at the inlets to deliver the system demand.

#### **4-3.5.3**

Where a fire department connection services only a portion of a building, a sign shall be attached indicating the portions of the building served.

#### **4-3.5.4\***

A fire department connection for each standpipe system shall be located not more than 100 ft (30.5 m) from the nearest fire hydrant connected to an approved water supply.

*Exception: The location of the fire department connection shall be permitted to exceed 100 ft (30.5 m) subject to the approval of the authority having jurisdiction.*

### **4-3.6**

Fire department connections shall be located not less than 18 in. (457 mm) nor more than 48 in. (1219 mm) above the level of the adjoining ground, sidewalk, or grade surface.

### **4-3.7**

Fire department connection piping shall be supported in accordance with Section 4-4.

## **4-4 Support of Piping.**

### **4-4.1 Support of Standpipes.**

#### **4-4.1.1**

Standpipes shall be supported by attachments connected directly to the standpipe.

#### **4-4.1.2**

Standpipe supports shall be provided at the lowest level, at each alternate level above the lowest level, and at the top of the standpipe. Supports above the lowest level shall restrain the pipe to prevent movement by an upward thrust where flexible fittings are used.

#### **4-4.1.3**

Clamps supporting pipe by means of set screws shall not be used.

### **4-4.2 Support of Horizontal Piping.**

#### **4-4.2.1**

**Copyright NFPA**

Horizontal piping from the standpipe to hose connections that are more than 18 in. (457 mm) in length shall be provided with hangers.

#### **4-4.2.2**

Horizontal piping hangers shall be spaced at a maximum separation distance of 15 ft (4.6 m). The piping shall be restrained to prevent movement by horizontal thrust where flexible fittings are used.

### **4-5 Installation and Maintenance of Hydrants.**

#### **4-5.1\***

Hydrants shall be set on flat stones or concrete slabs and shall be provided with small stones (or equivalent) placed about the drain to ensure drainage.

#### **4-5.2**

Where soil is of such a nature that the hydrants will not drain properly with the arrangement specified in 4-5.1, or groundwater stands at levels above that of the drain, the hydrant drain shall be plugged at the time of installation. If the drain is plugged, hydrants in service in cold climates shall be pumped out after usage. Such hydrants shall be marked to indicate the need for pumping out after usage.

#### **4-5.3\***

The center of a hose outlet shall be not less than 18 in. (457 mm) above final grade, or when located in a hose house, 12 in. (305 mm) above the floor.

#### **4-5.4**

Hydrants shall be fastened to piping and anchored in accordance with the requirements of NFPA 13, *Standard for the Installation of Sprinkler Systems*.

#### **4-5.5**

Hydrants shall be protected if subject to mechanical damage. The means of protection shall be arranged in a manner that will not interfere with the connection to, or operation of, hydrants.

#### **4-5.6**

Check valves, detector check valves, backflow prevention valves, and similar appurtenances shall not be installed in the service stub between a fire hydrant and private water supply piping.

### **4-6 Installation of Signs.**

Signs shall be secured to a device or the building wall with substantial and corrosion-resistant chains or fasteners.

### **4-7 Signs for Water Supply Pumps.**

Where a fire pump is provided, a sign shall be located in the vicinity of the pump indicating the minimum pressure and flow required at the pump discharge flange to meet the system demand.

### **4-8\* Hydraulic Design Information Sign.**

The installing contractor shall provide a sign identifying the basis of the system design as either hydraulic calculations or pipe schedule. The sign shall be located at the water supply control valve for automatic or semiautomatic standpipe systems and at an approved location for manual systems.

The sign shall indicate the following:

- (1) The location of the two hydraulically most remote hose connections
- (2) The design flow rate for the connections identified in 4-8(1)

- (3) The design residual inlet and outlet pressures for the connections identified in 4-8(1)
- (4) The design static pressure and the design system demand (i.e., flow and residual pressure) at the system control valve, or at the pump discharge flange where a pump is installed, and at each fire department connection

## Chapter 5 Design

### 5-1\* General.

The design of the standpipe system is governed by building height, area per floor occupancy classification, egress system design, required flow rate and residual pressure, and the distance of the hose connection from the source(s) of the water supply. (*See Chapter 3 for general system requirements.*)

### 5-2\* Pressure Limitation.

The maximum pressure at any point in the system at any time shall not exceed 350 psi (24.1 bar).

### 5-3 Locations of Hose Connections.

#### 5-3.1\* General.

Hose connections and hose stations shall be unobstructed and shall be located not less than 3 ft (0.9 m) or more than 5 ft (1.5 m) above the floor.

#### 5-3.2\* Class I Systems.

Class I systems shall be provided with 2<sup>1</sup>/<sub>2</sub>-in. (63.5-mm) hose connections in the following locations:

- (a) At each intermediate landing between floor levels in every required exit stairway.

*Exception: Hose connections shall be permitted to be located at the main floor landings in exit stairways where approved by the authority having jurisdiction.*

- (b) On each side of the wall adjacent to the exit openings of horizontal exits.
- (c) In each exit passageway at the entrance from the building areas into the passageway.
- (d) In covered mall buildings, at the entrance to each exit passageway or exit corridor, and at exterior public entrances to the mall.

(e) At the highest landing of stairways with stairway access to a roof, and on the roof where stairways do not access the roof. An additional 2<sup>1</sup>/<sub>2</sub>-in. (63.5-mm) hose connection shall be provided at the hydraulically most remote riser to facilitate testing of the system.

(f) \* Where the most remote portion of a nonsprinklered floor or story is located in excess of 150 ft (45.7 m) of travel distance from a required exit containing or adjacent to a hose connection, or the most remote portion of a sprinklered floor or story is located in excess of 200 ft (61 m) of travel distance from a required exit containing or adjacent to a hose connection, additional hose connections shall be provided, in approved locations, where required by the local fire department or the authority having jurisdiction.

#### 5-3.3\* Class II Systems.

Class II systems shall be provided with 1<sup>1</sup>/<sub>2</sub>-in. (38.1-mm) hose stations so that all portions of each floor level of the building are within 130 ft (39.7 m) of a hose connection provided with 1<sup>1</sup>/<sub>2</sub>-in. (38.1-mm) hose or within 120 ft (36.6 m) of a hose connection provided with less than 1<sup>1</sup>/<sub>2</sub>-in. (38.1-mm) hose. Distances shall be measured along a path of travel originating at the hose connection.

#### 5-3.4 Class III Systems.

Class III systems shall be provided with hose connections as required for both Class I and Class II systems.

#### 5-4 Number of Standpipes.

Separate standpipes shall be provided in each required exit stairway.

#### 5-5\* Interconnection of Standpipes.

Where two or more standpipes are installed in the same building or section of building, they shall be interconnected at the bottom. Where standpipes are supplied by tanks located at the top of the building or zone, they also shall be interconnected at the top; in such cases, check valves shall be installed at the base of each standpipe to prevent circulation.

#### 5-6 Minimum Sizes for Standpipes.

##### 5-6.1

Class I and Class III standpipes shall be at least 4 in. (102 mm) in size.

##### 5-6.2

Standpipes that are part of a combined system shall be at least 6 in. (152 mm) in size.

*Exception: In fully sprinklered buildings having a combined standpipe system that is hydraulically calculated, the minimum standpipe size is 4 in. (102 mm).*

#### 5-7\* Minimum Pressure for System Design and Sizing of Pipe.

Standpipe systems shall be designed so that the system demand can be supplied by both the attached water supply, where required, and fire department connections. The authority having jurisdiction shall be consulted regarding the water supply available from a fire department pumper.

Standpipe systems shall be one of the following:

- (1) Hydraulically designed to provide the required waterflow rate at a minimum residual pressure of 100 psi (6.9 bar) at the outlet of the hydraulically most remote 2½-in. (63.5-mm) hose connection and 65 psi (4.5 bar) at the outlet of the hydraulically most remote 1½-in. (38.1-mm) hose station.

*Exception No. 1: Where the authority having jurisdiction permits pressures lower than 100 psi (6.9 bar) for 2½-in. (63.5-mm) hose connections, based on suppression tactics, the pressure shall be permitted to be reduced to not less than 65 psi (4.5 bar).*

*Exception No. 2: In other than high-rise buildings, the authority having jurisdiction shall be allowed to reduce the minimum pressure requirements of this section if the building is protected throughout by an approved automatic sprinkler system.*

- (2) Sized in accordance with the pipe schedule in Table 5-7 to provide the required waterflow rate at a minimum residual pressure of 100 psi (6.9 bar) at the topmost 2½-in. (63.5-mm) hose connection and 65 psi (4.5 bar) at the topmost 1½-in. (38.1-mm) hose station. Pipe schedule designs shall be limited to wet standpipes for buildings that are not defined as high-rise.

**Table 5-7 Pipe Schedule — Standpipes and Supply Piping Minimum Nominal Pipe Sizes in Inches**

gpm	Total Accumulated Flow L/min	Total Distance of Piping from Farthest Outlet		
		<50 ft (<15.2 m)	50-100 ft (15.2-30.5 m)	>100 ft (>30.5 m)
100	379	2	2½	3
101-500	382-1893	4	4	6

Total Accumulated Flow		Total Distance of Piping from Farthest Outlet		
gpm	L/min	<50 ft (<15.2 m)	50-100 ft (15.2-30.5 m)	>100 ft (>30.5 m)
501-750	1896-2839	5	5	6
751-1250	2843-4731	6	6	6
1251 and over	4735	8	8	8

For SI units, 1 gpm = 3.785 L/min; 1 ft = 0.3048 m.

## 5-8\* Maximum Pressure for Hose Connections.

### 5-8.1

Where the residual pressure at a 1½-in. (38.1-mm) outlet on a hose connection available for occupant use exceeds 100 psi (6.9 bar), an approved pressure-regulating device shall be provided to limit the residual pressure at the flow required by Section 5-9 to 100 psi (6.9 bar).

### 5-8.2\*

Where the static pressure at a hose connection exceeds 175 psi (12.1 bar), an approved pressure-regulating device shall be provided to limit static and residual pressures at the outlet of the hose connection to 100 psi (6.9 bar) for 1½-in. (38.1-mm) hose connections available for occupant use and 175 psi (12.1 bar) for other hose connections. The pressure on the inlet side of the pressure-regulating device shall not exceed the device's rated working pressure.

## 5-9 Minimum Flow Rates.

### 5-9.1 Class I and Class III Systems.

#### 5-9.1.1\* Minimum Flow Rate.

For Class I and Class III systems, the minimum flow rate for the hydraulically most remote standpipe shall be 500 gpm (1893 L/min). The minimum flow rate for additional standpipes shall be 250 gpm (946 L/min) per standpipe, with the total not to exceed 1250 gpm (4731 L/min). For combined systems, see 5-9.1.3.

*Exception: When the floor area exceeds 80,000 ft<sup>2</sup> (7432 m<sup>2</sup>), the second most remote standpipe shall be designed to accommodate 500 gpm (1893 L/min).*

#### 5-9.1.2\* Hydraulic Calculation Procedure.

Hydraulic calculations and pipe sizes for each standpipe shall be based on providing 250 gpm (946 L/min) at the two hydraulically most remote hose connections on the standpipe and at the topmost outlet of each of the other standpipes at the minimum residual pressure required by Section 5-7. Common supply piping shall be calculated and sized to provide the required flow rate for all standpipes connected to such supply piping, with the total not to exceed 1250 gpm (4731 L/min).

#### 5-9.1.3 Combined Systems.

##### 5-9.1.3.1\*

For a building protected throughout by an approved automatic sprinkler system, the system demand established by Section 5-7 and 5-9.1 also shall be permitted to serve the sprinkler system. A separate sprinkler demand shall not be required.

*Exception: Where the sprinkler system water supply requirement, including the hose stream allowance as determined in accordance with NFPA 13, Standard for the Installation of Sprinkler Systems, exceeds the system demand established by Section 5-7 and 5-9.1, the larger of the two values shall be provided. The flow*

rate required for the standpipe demand of a combined system in a building protected throughout by an automatic sprinkler system shall not be required to exceed 1000 gpm (3785 L/min) unless required by the authority having jurisdiction.

**5-9.1.3.2**

For a combined system in a building equipped with partial automatic sprinkler protection, the flow rate required by 5-9.1 shall be increased by an amount equal to the hydraulically calculated sprinkler demand or 150 gpm (568 L/min) for light hazard occupancies, or by 500 gpm (1893 L/min) for ordinary hazard occupancies, whichever is less.

**5-9.1.3.3**

Where an existing standpipe system having standpipes with a minimum diameter of 4 in. (102 mm) is to be utilized to supply a new retrofit sprinkler system, the water supply required by 5-9.1 shall not be required to be provided by automatic or semiautomatic means if approved by the authority having jurisdiction, provided that the water supply is adequate to supply the hydraulic demand of the sprinkler system.

**5-9.2 Class II Systems.**

**5-9.2.1 Minimum Flow Rate.**

For Class II systems, the minimum flow rate for the hydraulically most remote standpipe shall be 100 gpm (379 L/min). Additional flow shall not be required where more than one standpipe is provided.

**5-9.2.2 Hydraulic Calculation Procedure.**

Hydraulic calculations and pipe sizes for each standpipe shall be based on providing 100 gpm (379 L/min) at the hydraulically most remote hose connection on the standpipe at the minimum residual pressure required by Section 5-7. Common supply piping serving multiple standpipes shall be calculated and sized to provide 100 gpm (379 L/min).

**5-10 Equivalent Pipe Lengths of Valves and Fittings for Hydraulically Designed Systems.**

**5-10.1 General.**

Table 5-10.1 shall be used to determine the equivalent length of pipe for fittings and devices unless the manufacturer’s test data indicate that other factors are appropriate. For saddle-type fittings having friction loss greater than that shown in Table 5-10.1, the increased friction loss shall be included in the hydraulic calculations.

**Table 5-10.1 Equivalent Pipe Length Chart**

Fittings and Valves	Fittings and Valves Expressed in Equivalent Feet of Pipe									
	3/4 in.	1 in.	1 1/4 in.	1 1/2 in.	2 in.	2 1/2 in.	3 in.	3 1/2 in.	4 in.	5 in.
45-degree elbow	1	1	1	2	2	3	3	3	4	5
90-degree standard elbow	2	2	3	4	5	6	7	8	10	12
90-degree long-turn elbow	1	2	2	2	3	4	5	5	6	8
Tee or cross (flow turned 90 degrees)	3	5	6	8	10	12	15	17	20	25
Butterfly valve	—	—	—	—	6	7	10	—	12	9
Gate valve	—	—	—	—	1	1	1	1	2	2
Swing check*	—	5	7	9	11	14	16	19	22	27
Globe valve	—	—	—	46	—	70	—	—	—	—
Angle valve	—	—	—	20	—	31	—	—	—	—

Fittings and Valves	Fittings and Valves Expressed in Equivalent Feet of Pipe									
	3/4 in.	1 in.	1 1/4 in.	1 1/2 in.	2 in.	2 1/2 in.	3 in.	3 1/2 in.	4 in.	5 in.
For SI units, 1 in. = 25.4 mm.										
* Due to the variations in design of swing check valves, the pipe equivalents indicated in this table are considered to be average.										

## 5-10.2 Adjustments.

Table 5-10.1 shall be used only where the Hazen-Williams *C* factor is 120. For other values of *C*, the values in Table 5-10.1 shall be multiplied by the factors indicated in Table 5-10.2(a). Table 5-10.2(b) indicates typical *C* factors for commonly used piping materials.

*Exception: The authority having jurisdiction shall be permitted to consider other C values.*

**Table 5-10.2(a) Adjustment Factors for *C* Values**

Value of <i>C</i>	100	130	140	150
Multiplying factor	0.713	1.16	1.33	1.51

**Table 5-10.2(b) Hazen-Williams *C* Values**

Pipe or Tube	<i>C</i> Value
Unlined cast or ductile iron	100
Black steel (dry systems, including preaction)	100
Black steel (wet systems, including deluge)	120
Galvanized (all)	120
Plastic (listed — all)	150
Cement-lined cast or ductile iron	140
Copper tube or stainless steel	150

## 5-11\* Drains and Test Riser.

### 5-11.1

A permanently installed 3-in. (76-mm) drain riser shall be provided adjacent to each standpipe equipped with pressure-regulating devices to facilitate tests of each device. The riser shall be equipped with a 3-in. ♂ 2 1/2-in. (76-mm ♂ 63.5-mm) tee with an internal threaded swivel fitting having NHS threads, as specified in NFPA 1963, *Standard for Fire Hose Connections*, with a plug, located on at least every other floor.

*Exception: Where local fire department hose threads do not conform to NFPA 1963, the authority having jurisdiction shall designate the hose threads to be used.*

### 5-11.2

Each standpipe shall be provided with a means of draining. A drain valve and piping, located at the lowest point of the standpipe piping downstream of the isolation valve, shall be arranged to discharge water at an approved location. Sizing shall be as specified in Table 5-11.2.

**Table 5-11.2 Sizing for Standpipe Drains**

Standpipe Size	Size of Drain Connection
----------------	--------------------------



Standpipe Size	Size of Drain Connection
Up to 2 in.	<sup>3</sup> / <sub>4</sub> in. or larger
2 <sup>1</sup> / <sub>2</sub> in., 3 in., or 3 <sup>1</sup> / <sub>2</sub> in.	1 <sup>1</sup> / <sub>4</sub> in. or larger
4 in. or larger	2 in. only

## **5-12\* Fire Department Connections.**

### **5-12.1**

One or more fire department connections shall be provided for each zone of each Class I or Class III standpipe system.

*Exception: The high zone fire department connection(s) shall not be required to be provided where 7-4.3 applies.*

### **5-12.2**

High-rise buildings shall have at least two remotely located fire department connections for each zone.

*Exception: A single connection for each zone shall be permitted where acceptable to the fire department.*

## **5-13 Number and Location of Hydrants.**

### **5-13.1\***

Hydrants shall be provided and spaced in accordance with the requirements of the authority having jurisdiction.

*Exception: Public hydrants are recognized as meeting all or part of the requirement of 5-13.1.*

### **5-13.2\***

Hydrants shall be placed a minimum of 40 ft (12.2 m) from the buildings protected.

*Exception: When hydrants cannot be placed at this distance, locations less than 40 ft (12.2 m) from the building or wall hydrants shall be permitted to be used (see Figure A-5-13.2).*

### **5-13.3**

Hydrants shall not be placed less than the equivalent depth of bury to retaining walls where there is danger of frost through the walls.

## **5-14 Hose Houses.**

### **5-14.1**

When hose houses are utilized, they shall be located over the hydrant or immediately adjacent. Hydrants within hose houses shall be as close to the front of the house as possible and still allow sufficient room back of the doors for the hose gates and the attached hose.

### **5-14.2**

When hose reels or hose carriers are utilized, they shall be located so that the hose can be brought into use at a hydrant. *(For equipment details when utilizing hose reels and hose carriers, see 2-6.2.6.)*

## **5-15\* Master Streams.**

### **5-15.1**

Master streams are delivered by monitor nozzles, hydrant-mounted monitor nozzles, and similar master stream equipment capable of delivering more than 250 gpm (946 L/min).

## 5-15.2

Master streams shall be provided as protection for large amounts of combustible materials located in yards, average amounts of combustible materials in inaccessible locations, or occupancies presenting special hazards as required by the authority having jurisdiction.

# Chapter 6 Plans and Calculations

## 6-1\* Plans and Specifications.

Plans accurately showing the details and arrangement of the standpipe system shall be furnished to the authority having jurisdiction prior to the installation of the system. Such plans shall be clear, legible, and drawn to scale. The drawings shall show the location, arrangement, water supply, equipment, and all other details necessary to establish compliance with this standard.

The plans shall include specifications covering the character of materials used and shall describe all system components. The plans shall include an elevation diagram.

## 6-2 Hydraulic Calculations.

Where standpipe system piping is sized by hydraulic calculations, a complete set of calculations shall be submitted with the plans.

# Chapter 7 Water Supplies

## 7-1\* Required Water Supply.

### 7-1.1

Automatic and semiautomatic standpipe systems shall be attached to an approved water supply capable of supplying the system demand. Manual standpipe systems shall have an approved water supply accessible to a fire department pumper.

A single automatic or semiautomatic water supply shall be permitted where it is capable of supplying the system demand for the required duration.

*Exception: Where a secondary water supply is required by 7-4.3.*

### 7-1.2\*

Water supplies from the following sources shall be permitted:

- (1) A public waterworks system where pressure and flow rate are adequate
- (2) Automatic fire pumps connected to an approved water source in accordance with NFPA 20, *Standard for the Installation of Stationary Pumps for Fire Protection*
- (3) Manually controlled fire pumps in combination with pressure tanks
- (4) Pressure tanks installed in accordance with NFPA 22, *Standard for Water Tanks for Private Fire Protection*
- (5) Manually controlled fire pumps operated by remote control devices at each hose station
- (6) Gravity tanks installed in accordance with NFPA 22, *Standard for Water Tanks for Private Fire Protection*

## 7-2 Minimum Supply for Class I and Class III Systems.

The water supply shall be sufficient to provide the system demand established by Section 5-7 and 5-9.1 for at least 30 minutes.

### **7-3 Minimum Supply for Class II Systems.**

The minimum supply for Class II systems shall be sufficient to provide the system demand established by Section 5-7 and 5-9.2 for at least 30 minutes.

### **7-4 Standpipe System Zones.**

Each zone requiring pumps shall be provided with a separate pump. This shall not preclude the use of pumps arranged in series.

#### **7-4.1**

Where pumps supplying two or more zones are located at the same level, each zone shall have separate and direct supply piping of a size not smaller than the standpipe that it serves. Zones with two or more standpipes shall have at least two direct supply pipes of a size not smaller than the largest standpipe that they serve.

#### **7-4.2**

Where the supply for each zone is pumped from the next lower zone, and the standpipe or standpipes in the lower zone are used to supply the higher zone, such standpipes shall comply with the provisions for supply lines in 7-4.1. At least two lines shall be provided between zones; one of these lines shall be arranged so that the supply can be automatically delivered from the lower to the higher zone.

#### **7-4.3**

For systems with two or more zones in which portions of the second and higher zones cannot be supplied using the residual pressure required by Section 5-7 by means of fire department pumpers through a fire department connection, an auxiliary means of supply shall be provided. This means shall be in the form of high-level water storage with additional pumping equipment or other means acceptable to the authority having jurisdiction.

## **Chapter 8 Water Supply Testing**

### **8-1\* Introduction.**

A waterflow test shall be conducted on the water distribution system to determine the rate of flow and pressures available for system design and for fire-fighting purposes.

### **8-2 Procedure.**

#### **8-2.1**

Tests shall be conducted during a period of expected normal demand. The procedure shall consist of discharging water at a measured rate of flow from the system at a given location and observing the corresponding pressure drop in the mains.

#### **8-2.2**

Tests for the purpose of system design shall not be conducted more than 9 months prior to the commencement of the system installation.

## **Chapter 9 System Acceptance**

### **9-1\* General.**

### **9-1.1**

All new systems shall be tested prior to the occupancy of the building. Existing standpipe systems that are to be utilized as standpipes for a combination system in the retrofit of a new sprinkler system shall be tested in accordance with Section 9-4.

### **9-1.2**

The installing contractor shall complete and sign the appropriate contractor's material and test certificate(s). [*See Figures 9-1.2(a) and 9-1.2(b).*]

## **9-2 Flushing of Piping.**

### **9-2.1**

Underground piping supplying the system shall be flushed in accordance with NFPA 24, *Standard for the Installation of Private Fire Service Mains and Their Appurtenances*.

### **9-2.2**

Piping between the fire department connection and the check valve in the inlet pipe shall be flushed with a sufficient volume of water in order to remove any construction debris and trash accumulated in the piping prior to the completion of the system and prior to the installation of the fire department connection.

## **9-3 Hose Threads.**

All hose connection and fire department connection threads shall be tested to verify their compatibility with threads used by the local fire department. The test shall consist of threading coupling samples, caps, or plugs onto the installed devices.

## **9-4 Hydrostatic Tests.**

### **9-4.1\* General.**

All new systems, including yard piping and fire department connections, shall be tested hydrostatically at not less than 200 psi (13.8 bar) of pressure for 2 hours, or at 50 psi (3.5 bar) in excess of the maximum pressure where the maximum pressure is in excess of 150 psi (10.3 bar). The hydrostatic test pressure shall be measured at the low elevation point of the individual system or zone being tested. The inside standpipe system piping shall show no leakage. Underground pipe shall be tested in accordance with NFPA 24, *Standard for the Installation of Private Fire Service Mains and Their Appurtenances*.

*Exception: Where cold weather prevents testing with water, an interim air test shall be permitted to be conducted prior to the standard hydrostatic test. An air pressure leakage test at 40 psi (2.8 bar) shall be conducted for 24 hours. Any leakage that results in a loss of pressure in excess of 1½ psi (0.1 bar) during a continuous 24-hour period shall be corrected.*

### **9-4.2 Fire Department Connection.**

Piping between the fire department connection and the check valve in the inlet pipe shall be tested hydrostatically in the same manner as the balance of the system.

### **9-4.3 Existing Systems.**

Where an existing standpipe system, including yard piping and fire department connection, is modified, the new piping shall be tested in accordance with 9-4.1.

### **9-4.4 Protection from Freezing.**

During testing, care shall be taken to ensure that no portion of the piping is subject to freezing during cold weather.

#### **9-4.5 Gauges.**

During the hydrostatic test, the pressure gauge at the top of each standpipe shall be observed and the pressure recorded.

#### **9-4.6 Water Additives.**

Additives, corrosive chemicals such as sodium silicate or derivatives of sodium silicate, brine, or other chemicals shall not be used while hydrostatically testing systems or for stopping leaks.

#### **9-5 Flow Tests.**

##### **9-5.1\***

The water supply shall be tested to verify compliance with the design. This test shall be conducted by flowing water from the hydraulically most remote hose connections.

##### **9-5.2**

For a manual standpipe, a fire department pumper or portable pump of adequate capacity (i.e., required flow and pressure) shall be used to verify the system design by pumping into the fire department connection.

##### **9-5.3**

A flow test shall be conducted at each roof outlet to verify that the required pressure is available at the required flow.

##### **9-5.4**

The filling arrangement for suction tanks shall be verified by shutting down all supplies to the tank, draining the tank to below the designated low water level, and then opening the supply valve to ensure operation of its automatic features.

#### **9-5.5 Pressure-Regulating Devices.**

Each pressure-regulating device shall be tested to verify that the installation is correct, that the device is operating properly, and that the inlet and outlet pressures at the device are in accordance with the design. Static and residual inlet pressure and static and residual outlet pressure and flow shall be recorded on the contractor's test certificate.

#### **9-5.6 Main Drain Flow Test.**

The main drain valve shall be opened and shall remain open until the system pressure stabilizes. The static and residual pressure shall be recorded on the contractor's test certificate.

#### **9-5.7 Testing of Automatic- and Semiautomatic-Dry Systems.**

Automatic- and semiautomatic-dry systems shall be tested by initiating a flow of water from the hydraulically most remote hose connection. The system shall deliver a minimum of 250 gpm (946 L/min) at the hose connection within 3 minutes of opening the hose valve. Each remote control device for operating a semiautomatic system shall be tested in accordance with the manufacturer's instructions.

#### **9-5.8 Systems Having Pumps.**

Where pumps are part of the water supply for a standpipe system, testing shall be conducted while the pumps are operating.

#### **9-6 Manual Valve Test.**

Each valve intended to be manually opened or closed shall be operated by turning the handwheel crank or wrench for its full range and returning it to its normal position. Hose valve caps shall be tightened sufficiently to avoid leaking during the test and removed after the test to drain water and relieve pressure.

## 9-7 Alarm and Supervision Tests.

Each alarm and supervisory device provided shall be tested in accordance with NFPA 72, *National Fire Alarm Code*®.

**Figure 9-1.2(a) Sample contractor's material and test certificate for aboveground piping.**

<b>Contractor's Material and Test Certificate for <big>A</big>boveground Piping</b> Standpipe System NFPA 14	
<b>PROCEDURE</b> Upon completion of work, inspection and tests shall be made by the contractor's representative and witnessed by an owner's representative. All defects shall be corrected and system left in service before contractor's personnel finally leave the job.  A certificate shall be filled out and signed by both representatives. Copies shall be prepared for approving authorities, owners, and contractor. It is understood the owner's representative's signature in no way prejudices any claim against contractor for faulty material, poor workmanship, or failure to comply with approving authority's requirements or local ordinances.	
PROPERTY NAME	DATE
PROPERTY ADDRESS	
PLANS	ACCEPTED BY APPROVING AUTHORITIES (NAMES)
	ADDRESS
	INSTALLATION CONFORMS TO ACCEPTED PLANS <input type="checkbox"/> YES <input type="checkbox"/> NO
	EQUIPMENT USED IS APPROVED OR LISTED <input type="checkbox"/> YES <input type="checkbox"/> NO IF NO, EXPLAIN DEVIATIONS
TYPE OF SYSTEM	AUTOMATIC-DRY <input type="checkbox"/> YES
	AUTOMATIC-WET <input type="checkbox"/> YES
	SEMI-AUTOMATIC-DRY <input type="checkbox"/> YES
	MANUAL-DRY <input type="checkbox"/> YES
	MANUAL-WET <input type="checkbox"/> YES
	COMBINATION STANDPIPE/SPRINKLER <input type="checkbox"/> YES
	OTHER, IF YES EXPLAIN <input type="checkbox"/> YES
WATER SUPPLY DATA USED FOR DESIGN AND AS SHOWN ON PLANS	FIRE PUMP DATA
	MANUFACTURER _____ MODEL _____
	TYPE: <input type="checkbox"/> ELECTRIC <input type="checkbox"/> DIESEL <input type="checkbox"/> OTHER, EXPLAIN _____
	RATED GPM _____ RATED PSI _____ SHUT-OFF PSI _____
WATER SUPPLY SOURCE CAPACITY, GALLONS	PUBLIC WATER-WORKS SYSTEM <input type="checkbox"/> STORAGE TANK <input type="checkbox"/> GRAVITY TANK <input type="checkbox"/> OPEN RESERVOIR <input type="checkbox"/>
	OTHER <input type="checkbox"/> EXPLAIN _____
IF PUBLIC WATERWORKS SYSTEM:	STATIC PSI _____ RESIDUAL PSI _____ GPM _____ FLOW IN _____
HAVE COPIES OF THE FOLLOWING BEEN LEFT ON THE PREMISES?	<input type="checkbox"/> SYSTEM COMPONENTS INSTRUCTIONS <input type="checkbox"/> CARE AND MAINTENANCE OF SYSTEM <input type="checkbox"/> NFPA 25
	<input type="checkbox"/> COPY OF ACCEPTED PLANS <input type="checkbox"/> HYDRAULIC DATA/CALCULATIONS
SUPPLIES BUILDING(S)	MAIN WATERFLOW SHUT-OFF LOCATION _____
	NUMBER OF STANDPIPE RISERS _____
	DO ALL STANDPIPE RISERS HAVE BASE OF RISER SHUT-OFF VALVES? <input type="checkbox"/> YES <input type="checkbox"/> NO
VALVE SUPERVISION	LOCKED OPEN <input type="checkbox"/> SEALED AND TAGGED <input type="checkbox"/> TAMPERPROOF SWITCH <input type="checkbox"/> OTHER <input type="checkbox"/> IF OTHER, _____
PIPE AND FITTINGS	TYPE OF PIPE _____
	TYPE OF FITTINGS _____
BACKFLOW PREVENTOR	A) DOUBLE CHECK ASSEMBLY <input type="checkbox"/> SIZE _____ MAKE AND MODEL _____
	B) REDUCED-PRESSURE DEVICE <input type="checkbox"/>

(NFPA 14, 1 of 3)

**Figure 9-1.2(a) Continued.**

CONTROL VALVE DEVICE						
TYPE	SIZE	MAKE	MODEL			
TIME TO TRIP THROUGH REMOTE HOSE VALVE _____ MIN _____ SEC    WATER PRESSURE _____ AIR PRESSURE _____ TIME WATER REACHED REMOTE HOSE VALVE OUTLET _____ MIN _____ SEC    TRIP POINT AIR PRESSURE _____ PSI ALARM OPERATED PROPERLY <input type="checkbox"/> YES <input type="checkbox"/> NO    IF NO, EXPLAIN _____						
TIME WATER REACHED REMOTE HOSE VALVE OUTLET _____ MIN _____ SEC HYDRAULIC ACTIVATION <input type="checkbox"/> YES ELECTRIC ACTIVATION <input type="checkbox"/> YES PNEUMATIC ACTIVATION <input type="checkbox"/> YES MAKE AND MODEL OF ACTIVATION DEVICE _____ EACH ACTIVATION DEVICE TESTED <input type="checkbox"/> YES <input type="checkbox"/> NO    IF NO, EXPLAIN _____						
EACH ACTIVATION DEVICE OPERATED PROPERLY <input type="checkbox"/> YES <input type="checkbox"/> NO    IF NO, EXPLAIN _____						
PRESSURE-REGULATING DEVICE						
LOCATION & FLOOR	MODEL	NONFLOWING (PSI)		FLOWING (PSI)		GPM
		INLET	OUTLET	INLET	OUTLET	
ALL HOSE VALVES ON SYSTEM OPERATED PROPERLY <input type="checkbox"/> YES <input type="checkbox"/> NO    IF NO, EXPLAIN _____						

(NFPA 14, 2 of 3)

**Figure 9-1.2(a) Continued.**

TEST DESCRIPTION	<p>HYDROSTATIC: HYDROSTATIC TESTS SHALL BE MADE AT NOT LESS THAN 200 PSI (13.6 BAR) FOR 2 HOURS OR 50 PSI (3.4 BAR) ABOVE STATIC PRESSURE IN EXCESS OF 150 PSI (10.2 BAR) FOR 2 HOURS. DIFFERENTIAL DRY PIPE VALVE CLAPPERS SHALL BE LEFT OPEN DURING TEST TO PREVENT DAMAGE. ALL ABOVEGROUND PIPING LEAKAGE SHALL BE STOPPED.</p> <p>PNEUMATIC: ESTABLISH 40 PSI (2.7 BAR) AIR PRESSURE AND MEASURE DROP, WHICH SHALL NOT EXCEED 1½ PSI (0.1 BAR) IN 24 HOURS. TEST PRESSURE TANKS AT NORMAL WATER LEVEL AND AIR PRESSURE AND MEASURE AIR PRESSURE DROP, WHICH SHALL NOT EXCEED 1½ PSI (0.1 BAR) IN 24 HOURS.</p>		
TESTS	ALL PIPING HYDROSTATICALLY TESTED AT _____ PSI FOR _____ HRS DRY PIPING PNEUMATICALLY TESTED <input type="checkbox"/> YES <input type="checkbox"/> NO EQUIPMENT OPERATES PROPERLY <input type="checkbox"/> YES <input type="checkbox"/> NO		IF NO, STATE REASON
	DO YOU CERTIFY AS THE STANDPIPE CONTRACTOR THAT ADDITIVES AND CORROSIVE CHEMICALS, SODIUM SILICATE, OR DERIVATIVES OF SODIUM SILICATE, BRINE, OR OTHER CORROSIVE CHEMICALS WERE NOT USED FOR TESTING SYSTEMS OR STOPPING LEAKS? <input type="checkbox"/> YES <input type="checkbox"/> NO		
	DRAIN TEST	READING OF GAUGE LOCATED NEAR WATER SUPPLY TEST CONNECTION _____ PSI	RESIDUAL PRESSURE WITH VALVE IN TEST CONNECTION OPEN WIDE _____ PSI
	UNDERGROUND MAINS AND LEAD-IN CONNECTIONS TO SYSTEM RISERS FLUSHED BEFORE CONNECTION MADE TO STANDPIPE PIPING. VERIFIED BY COPY OF THE U FORM NO. 85B <input type="checkbox"/> YES <input type="checkbox"/> NO OTHER EXPLAIN FLUSHED BY INSTALLER OF UNDERGROUND STANDPIPE PIPING <input type="checkbox"/> YES <input type="checkbox"/> NO		
BLANK TESTING	NUMBER USED	LOCATIONS	NUMBER REMOVED
WELDING	WELDED PIPING <input type="checkbox"/> YES <input type="checkbox"/> NO IF YES ...		
	DO YOU CERTIFY AS THE STANDPIPE CONTRACTOR THAT WELDING PROCEDURES COMPLY WITH THE REQUIREMENTS OF AT LEAST AWS D10.9, LEVEL AR-3 <input type="checkbox"/> YES <input type="checkbox"/> NO DO YOU CERTIFY THAT THE WELDING WAS PERFORMED BY WELDERS QUALIFIED IN COMPLIANCE WITH THE REQUIREMENTS OF AT LEAST AWS D10.9, LEVEL AR-3 <input type="checkbox"/> YES <input type="checkbox"/> NO DO YOU CERTIFY THAT WELDING WAS CARRIED OUT IN COMPLIANCE WITH A DOCUMENTED QUALITY CONTROL PROCEDURE TO ENSURE THAT ALL DISCS ARE RETRIEVED, THAT OPENINGS IN PIPING ARE SMOOTH, THAT SLAG AND OTHER WELDING RESIDUE ARE REMOVED, AND THAT THE INTERNAL DIAMETERS OF PIPING ARE NOT PENETRATED <input type="checkbox"/> YES <input type="checkbox"/> NO		
	DO YOU CERTIFY THAT YOU HAVE A CONTROL FEATURE TO ENSURE THAT ALL CUTOUTS (DISCS) ARE RETRIEVED? <input type="checkbox"/> YES <input type="checkbox"/> NO		
CUTOUTS (DISCS)			
HYDRAULIC DATA NAMEPLATE	NAME PLATE PROVIDED <input type="checkbox"/> YES <input type="checkbox"/> NO IF NO, EXPLAIN		
REMARKS	DATE LEFT IN SERVICE WITH ALL CONTROL VALVES OPEN:		
NAME OF SPRINKLER/STANDPIPE CONTRACTOR	NAME OF CONTRACTOR _____ ADDRESS _____ STATE LICENSE NUMBER (IF APPLICABLE) _____		
SYSTEM OPERATING TEST WITNESSED BY	PROPERTY OWNER _____ TITLE _____ DATE _____ SPRINKLER/STANDPIPE CONTRACTOR _____ TITLE _____ DATE _____ APPROVING AUTHORITIES _____ TITLE _____ DATE _____		
ADDITIONAL EXPLANATION AND NOTES			

(NFPA 14, 3 of 3)

Figure 9-1.2(b) Sample contractor’s material and test certificate for underground piping.



## Contractor's Material and Test Certificate for **U**nderground Piping

**PROCEDURE**

Upon completion of work, inspection and tests shall be made by the contractor's representative and witnessed by an owner's representative. All defects shall be corrected and system left in service before contractor's personnel finally leave the job.

A certificate shall be filled out and signed by both representatives. Copies shall be prepared for approving authorities, owners, and contractor. It is understood the owner's representative's signature in no way prejudices any claim against contractor for faulty material, poor workmanship, or failure to comply with approving authority's requirements or local ordinances.

PROPERTY NAME	DATE
---------------	------

PROPERTY ADDRESS

PLANS	ACCEPTED BY APPROVING AUTHORITIES (NAMES)		
	ADDRESS		
	INSTALLATION CONFORMS TO ACCEPTED PLANS	<input type="checkbox"/> YES	<input type="checkbox"/> NO
	EQUIPMENT USED IS APPROVED IF NO, STATE DEVIATIONS	<input type="checkbox"/> YES	<input type="checkbox"/> NO

INSTRUCTIONS	HAS PERSON IN CHARGE OF FIRE EQUIPMENT BEEN INSTRUCTED AS TO LOCATION OF CONTROL VALVES AND CARE AND MAINTENANCE OF THIS NEW EQUIPMENT? IF NO, EXPLAIN	<input type="checkbox"/> YES	<input type="checkbox"/> NO
	HAVE COPIES OF APPROPRIATE INSTRUCTIONS AND CARE AND MAINTENANCE CHARTS BEEN LEFT ON PREMISES? IF NO, EXPLAIN	<input type="checkbox"/> YES	<input type="checkbox"/> NO

LOCATION SUPPLIES BUILDINGS

UNDERGROUND PIPES AND JOINTS	PIPE TYPES AND CLASS		TYPE JOINT	
	PIPE CONFORMS TO _____ STANDARD	<input type="checkbox"/> YES	<input type="checkbox"/> NO	
	FITTINGS CONFORM TO _____ STANDARD	<input type="checkbox"/> YES	<input type="checkbox"/> NO	
	IF NO, EXPLAIN			
	JOINTS NEEDING ANCHORAGE CLAMPED, STRAPPED, OR BLOCKED IN ACCORDANCE WITH _____ STANDARD	<input type="checkbox"/> YES	<input type="checkbox"/> NO	
	IF NO, EXPLAIN			

**TEST DESCRIPTION**

**FLUSHING:** Flow the required rate until water is clear as indicated by no collection of foreign material in burlap bags at outlets such as hydrants and blow-offs. Flush at flows not less than 390 gpm (1476 L/min) for 4-in. pipe, 880 gpm (3331 L/min) for 6-in. pipe, 1560 gpm (5905 L/min) for 8-in. pipe, 2440 gpm (9235 L/min) for 10-in. pipe, and 3520 gpm (13,323 L/min) for 12-in. pipe. When supply cannot produce stipulated flow rates, obtain maximum available.

**HYDROSTATIC:** Hydrostatic tests shall be made at not less than 200 psi (13.8 bar) for 2 hours or 50 psi (3.4 bar) above static pressure in excess of 150 psi (10.3 bar) for 2 hours.

**LEAKAGE:** New pipe laid with rubber gasketed joints shall, if the workmanship is satisfactory, have little or no leakage at the joints. The amount of leakage at the joints shall not exceed 2 qt/hr (1.89 L/hr) per 100 joints irrespective of pipe diameter. The leakage shall be distributed over all joints. If such leakage occurs at a few joints the installation shall be considered unsatisfactory and necessary repairs made. The amount of allowable leakage specified above can be increased by 1 fl oz per in. valve diameter per hr (30 mL/25 mm/hr) for each metal seated valve isolating the test section. If dry barrel hydrants are tested with the main valve open, so the hydrants are under pressure, an additional 5 oz/min (150 mL/min) leakage is permitted for each hydrant.

FLUSHING TESTS	NEW UNDERGROUND PIPING FLUSHED ACCORDING TO _____ STANDARD BY (COMPANY)		<input type="checkbox"/> YES	<input type="checkbox"/> NO
	IF NO, EXPLAIN			
	HOW FLUSHING FLOW WAS OBTAINED <input type="checkbox"/> PUBLIC WATER <input type="checkbox"/> TANK OR RESERVOIR <input type="checkbox"/> FIRE PUMP		THROUGH WHAT TYPE OPENING <input type="checkbox"/> HYDRANT BUTT <input type="checkbox"/> OPEN PIPE	
	LEAD-INS FLUSHED ACCORDING TO _____ STANDARD BY (COMPANY)		<input type="checkbox"/> YES	<input type="checkbox"/> NO
	IF NO, EXPLAIN			
	HOW FLUSHING FLOW WAS OBTAINED <input type="checkbox"/> PUBLIC WATER <input type="checkbox"/> TANK OR RESERVOIR <input type="checkbox"/> FIRE PUMP		THROUGH WHAT TYPE OPENING <input type="checkbox"/> Y CONN. TO FLANGE <input type="checkbox"/> OPEN PIPE & SPIGOT	

(NFPA 14, 1 of 2)

**Figure 9-1.2(b) Continued.**

HYDROSTATIC TEST	ALL NEW UNDERGROUND PIPING HYDROSTATICALLY TESTED AT _____ PSI FOR _____ HOURS		JOINTS COVERED <input type="checkbox"/> YES <input type="checkbox"/> NO
	TOTAL AMOUNT OF LEAKAGE MEASURED _____ GAL _____ HOURS		
LEAKAGE TEST	ALLOWABLE LEAKAGE _____ GAL _____ HOURS		
	NUMBER INSTALLED	TYPE AND MAKE	ALL OPERATE SATISFACTORILY <input type="checkbox"/> YES <input type="checkbox"/> NO
CONTROL VALVES	WATER CONTROL VALVES LEFT WIDE OPEN IF NO, STATE REASON		<input type="checkbox"/> YES <input type="checkbox"/> NO
	HOSE THREADS OF FIRE DEPARTMENT CONNECTIONS AND HYDRANTS INTERCHANGEABLE WITH THOSE OF FIRE DEPARTMENT ANSWERING ALARM		<input type="checkbox"/> YES <input type="checkbox"/> NO
REMARKS	DATE LEFT IN SERVICE		
SIGNATURES	NAME OF INSTALLING CONTRACTOR		
	TESTS WITNESSED BY		
	FOR PROPERTY OWNER (SIGNED)	TITLE	DATE
	FOR INSTALLING CONTRACTOR (SIGNED)	TITLE	DATE
ADDITIONAL EXPLANATION AND NOTES			

(NFPA 14, 2 of 2)

### 9-8 Instructions.

The installing contractor shall provide the owner with the following:

- (1) All literature and instructions provided by the manufacturer describing the proper operation and maintenance of equipment and devices installed
- (2) A copy of NFPA 25, *Standard for the Inspection, Testing, and Maintenance of Water-Based Fire Protection Systems*

### 9-9 Signs.

The installation of signs required by this standard shall be verified.

## Chapter 10 Buildings under Construction

### 10-1 General.

Where required by the authority having jurisdiction, a standpipe system, either temporary or permanent, shall be provided in accordance with this chapter in buildings under construction.

### 10-2 Fire Department Connections.

The standpipes shall be provided with conspicuously marked and readily accessible fire department connections on the outside of the building at the street level.

### 10-3 Other System Features.

Pipe sizes, hose connections, hose, water supply, and other details for new construction shall be in accordance with this standard.

#### **10-4 Support of Piping.**

Standpipes shall be supported and restrained securely at each alternate floor.

#### **10-5\* Hose Connections.**

At least one hose connection shall be provided at each floor level. Hose valves shall be kept closed at all times and guarded against mechanical injury.

#### **10-6\* Extension of System Piping.**

Standpipes shall be extended upward for each story and securely capped at the top.

#### **10-7 Temporary Installations.**

Temporary standpipes shall remain in service until the permanent standpipe is complete. Where temporary standpipes normally contain water, the piping shall be protected against freezing.

#### **10-8 Timing of Water Supply Installation.**

Where construction reaches a height at which public waterworks system pressure is no longer adequate, temporary or permanent fire pumps shall be installed to provide protection to the uppermost level or to the height required by the authority having jurisdiction.

*Exception: Where local fire department pumping apparatus is deemed by the authority having jurisdiction as adequate for the standpipe pressure required.*

#### **10-9 Protection of Hose Connections and Fire Department Connections.**

Threaded caps and plugs shall be installed on fire department connections and hose connections. Fire department connections and hose connections shall be protected against physical damage.

## **Chapter 11 Referenced Publications**

### **11-1**

The following documents or portions thereof are referenced within this standard as mandatory requirements and shall be considered part of the requirements of this standard. The edition indicated for each referenced mandatory document is the current edition as of the date of the NFPA issuance of this standard. Some of these mandatory documents might also be referenced in this standard for specific informational purposes and, therefore, are also listed in Appendix C.

#### **11-1.1 NFPA Publications.**

National Fire Protection Association, 1 Batterymarch Park, P.O. Box 9101, Quincy, MA 02269-9101.

NFPA 13, *Standard for the Installation of Sprinkler Systems*, 1999 edition.

NFPA 20, *Standard for the Installation of Stationary Pumps for Fire Protection*, 1999 edition.

NFPA 22, *Standard for Water Tanks for Private Fire Protection*, 1998 edition.

NFPA 24, *Standard for the Installation of Private Fire Service Mains and Their Appurtenances*, 1995 edition.

NFPA 25, *Standard for the Inspection, Testing, and Maintenance of Water-Based Fire Protection Systems*, 1998 edition.

NFPA 72, *National Fire Alarm Code*<sup>®</sup>, 1999 edition.

NFPA 1963, *Standard for Fire Hose Connections*, 1998 edition.

## **11-1.2 Other Publications.**

### **11-1.2.1 ANSI Publications.**

American National Standards Institute, Inc., 11 West 42nd Street, 13th Floor, New York, NY 10036.

ANSI B16.1, *Cast Iron Pipe Flanges and Flanged Fittings*, 1998.

ANSI B16.3, *Malleable Iron Threaded Fittings*, 1998.

ANSI B16.4, *Gray Iron Threaded Fittings*, 1992.

ANSI B16.5, *Pipe Flanges and Flanged Fittings*, 1996.

ANSI B16.9, *Factory-Made Wrought Steel Butt welding Fittings*, 1993.

ANSI B16.11, *Forged Fittings, Socket-Welding and Threaded*, 1996.

ANSI B16.18, *Cast Copper Alloy Solder Joint Pressure Fittings*, 1984.

ANSI B16.22, *Wrought Copper and Copper Alloy Solder Joint Pressure Fittings*, 1995.

ANSI B16.25, *Butt welding Ends*, 1992.

ANSI B36.10M, *Welded and Seamless Wrought Steel Pipe*, 1996.

### **11-1.2.2 ASTM Publications.**

American Society for Testing and Materials, 100 Barr Harbor Drive, West Conshohocken, PA 19428-2959.

ASTM A 53, *Standard Specification for Pipe, Steel, Black and Hot-Dipped, Zinc-Coated, Welded and Seamless*, 1999.

ASTM A 135, *Standard Specification for Electric-Resistance-Welded Steel Pipe*, 1997.

ASTM A 234, *Standard Specification for Piping Fittings of Wrought Carbon Steel and Alloy Steel for Moderate and High Temperature Service*, 1999.

ASTM A 795, *Standard Specification for Black and Hot-Dipped Zinc-Coated (Galvanized) Welded and Seamless Steel Pipe for Fire Protection Use*, 1997.

ASTM B 75, *Standard Specification for Seamless Copper Tube*, 1997.

ASTM B 88, *Standard Specification for Seamless Copper Water Tube*, 1996.

ASTM B 251, *Standard Specification for General Requirements for Wrought Seamless Copper and Copper-Alloy Tube*, 1997.

ASTM E 380, *Standard Practice for Use of the International System of Units (SI)*, 1993.

### **11-1.2.3 AWS Publication.**

American Welding Society, 550 N.W. LeJeune Road, Miami, FL 33126.

AWS A5.8, *Specification for Filler Metals for Brazing and Braze Welding*, 1992.

### **11-1.2.4 AWWA Publications.**

American Water Works Association, 6666 West Quincy Avenue, Denver, CO 80235.

AWWA C104, *Cement-Mortar Lining for Ductile-Iron Pipe and Fittings for Water*, 1990.

AWWA C110, *Ductile-Iron and Gray-Iron Fittings, 3 in. Through 48 in. (75 mm Through 1200 mm) for Water and Other Liquids*, 1993.

AWWA C151, *Ductile-Iron Pipe, Centrifugally Cast, for Water or Other Liquids*, 1991.

## Appendix A Explanatory Material

*Appendix A is not a part of the requirements of this NFPA document but is included for informational purposes only. This appendix contains explanatory material, numbered to correspond with the applicable text paragraphs.*

### **A-1-1**

See NFPA 25, *Standard for the Inspection, Testing, and Maintenance of Water-Based Fire Protection Systems*.

#### **A-1-4.1 Approved.**

The National Fire Protection Association does not approve, inspect, or certify any installations, procedures, equipment, or materials; nor does it approve or evaluate testing laboratories. In determining the acceptability of installations, procedures, equipment, or materials, the authority having jurisdiction may base acceptance on compliance with NFPA or other appropriate standards. In the absence of such standards, said authority may require evidence of proper installation, procedure, or use. The authority having jurisdiction may also refer to the listings or labeling practices of an organization that is concerned with product evaluations and is thus in a position to determine compliance with appropriate standards for the current production of listed items.

#### **A-1-4.2 Authority Having Jurisdiction.**

The phrase “authority having jurisdiction” is used in NFPA documents in a broad manner, since jurisdictions and approval agencies vary, as do their responsibilities. Where public safety is primary, the authority having jurisdiction may be a federal, state, local, or other regional department or individual such as a fire chief; fire marshal; chief of a fire prevention bureau, labor department, or health department; building official; electrical inspector; or others having statutory authority. For insurance purposes, an insurance inspection department, rating bureau, or other insurance company representative may be the authority having jurisdiction. In many circumstances, the property owner or his or her designated agent assumes the role of the authority having jurisdiction; at government installations, the commanding officer or departmental official may be the authority having jurisdiction.

#### **A-1-4.14 Listed.**

The means for identifying listed equipment may vary for each organization concerned with product evaluation; some organizations do not recognize equipment as listed unless it is also labeled. The authority having jurisdiction should utilize the system employed by the listing organization to identify a listed product.

#### **A-1-4.20 Pressure-Reducing Valve.**

A pressure relief valve is not a pressure-reducing valve and should not be used as such.

### **A-2-1**

The use of standard-weight valves and fittings ordinarily should be confined to the upper stories of very high buildings and to equipment in which the highest available pressures are less than 175 psi (12.1 bar).

#### **A-2-6.2.1**

All hose should not be removed from a hose house for testing at the same time because the time lost in returning it in case of fire could allow the fire to spread beyond control. See NFPA 1962, *Standard for the Care, Use, and Service Testing of Fire Hose Including Couplings and Nozzles*.

#### **A-2-6.2.2**

This can be done by storing hose in hose houses or by placing hose reels or hose carriers in weatherproof enclosures.

#### A-2-6.2.4

Typical hose houses are shown in Figures A-2-6.2.4(a) through A-2-6.2.4(c).

**Figure A-2-6.2.4(a) House of five-sided design for installation over a private hydrant.**



**Figure A-2-6.2.4(b) Steel house (shown closed) of compact dimensions for installation over a private hydrant, in which top lifts up and doors on front side open for complete accessibility.**



**Figure A-2-6.2.4(c) This type of hose house can be installed on legs as shown or installed on a wall near, but not directly over, a private hydrant.**



#### A-2-6.2.6.1

Desirable optional equipment to be included in hose house equipment is as follows:

- (1) One fire axe with brackets
- (2) One crowbar with brackets

- (3) Two hose and ladder straps
- (4) Two electrical battery hand lights

### **A-2-8**

See Figure A-4-3 for general arrangement.

#### **A-2-8.2**

See Sections 5-7 and 5-12 for design requirements.

### **A-2-9**

Hydrants should be classified in accordance with their rated capacities [at 20-psi (1.4-bar) residual pressure or other designated value] as follows:

- (1) Class AA — rated capacity of 1500 gpm (5680 L/min) or greater
- (2) Class A — rated capacity of 1000-1499 gpm (3785-5675 L/min)
- (3) Class B — rated capacity of 500-999 gpm (1900-3780 L/min)
- (4) Class C — rated capacity of less than 500 gpm (1900 L/min)

#### **A-2-9.2**

All barrels should be white except in cases where another color has already been adopted. The tops and nozzle caps should be painted with the following capacity-indicating color scheme to provide simplicity and consistency with colors used in signal work for safety, danger, and intermediate condition:

- (1) Class AA — light blue
- (2) Class A — green
- (3) Class B — yellow
- (4) Class C — red

For rapid identification at night, it is recommended that the capacity colors be of a reflective-type paint.

Hydrants rated at less than 20 psi (1.4 bar) should have the rated pressure stenciled in black on the hydrant top.

In addition to the painted top and nozzle caps, it can be advantageous to stencil the rated capacity of high volume hydrants on the top.

The classification and marking of hydrants provided for in Chapter 2 anticipate determination based on individual flow test. Where a group of hydrants can be used at the time of a fire, some special marking designating group-flow capacity can be desirable.

#### **A-2-9.3**

Location markers for flush hydrants should carry the same color background as stated in A-2-9.2 for class indication, with such other data stenciled thereon as deemed necessary.

Marking on private hydrants within private enclosures is to be at the owner's discretion. When private hydrants are located on public streets, they should be painted red, or some other color, to distinguish them from public hydrants.

#### **A-3-2.1.1**

Fire hydrants that are permanently inoperative should be removed. Prior to removal, hydrants should be painted black.

#### **A-3-2.1.2**

Fire hydrants that are temporarily inoperative or unusable should be wrapped, bagged, or otherwise provided with

visible indication of their condition.

### A-3-6

Additional pressure gauges located at the base of the standpipes could be desirable in some equipment, particularly in large plants and high-rise buildings.

### A-3-7

Audible alarms are normally located on the outside of the building. Approved electric gong bells, horns, or sirens located inside the building, or both inside and outside, are sometimes advisable.

### A-4-1

Connections from fire pumps and sources outside the building should be made at the base of the standpipes.

#### A-4-1.2.1

Standpipes should not be placed in unsprinklered areas of combustible construction.

#### A-4-2.5.2

Combined automatic sprinkler and standpipe risers should not be interconnected by sprinkler system piping.

#### A-4-2.6.2

See NFPA 24, *Standard for the Installation of Private Fire Service Mains and Their Appurtenances*.

### A-4-3

See Figure A-4-3 for general arrangement.

**Figure A-4-3 Typical fire department connection for wet standpipes.**

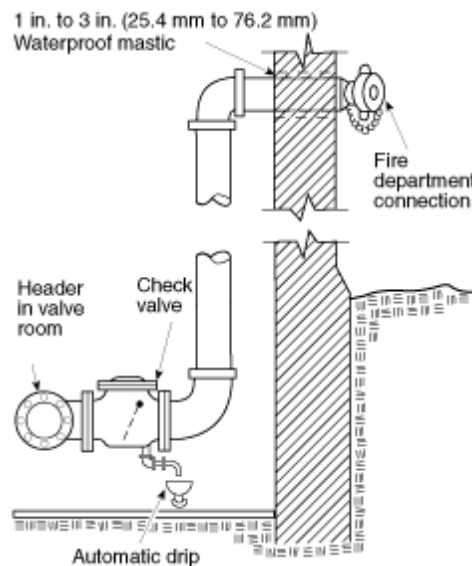

#### A-4-3.5.4

The system designer should contact the authority having jurisdiction prior to establishing the location of the fire department connection. The location should be based on the requirements of the fire department.

#### A-4-5.1

See Figure A-4-5.1.



**Figure A-4-5.1 Typical hydrant connection.**

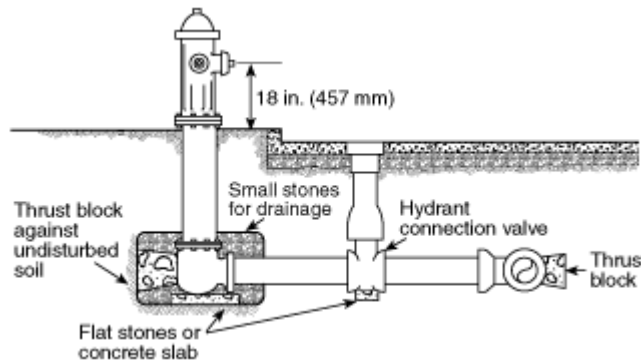

**A-4-5.3**

In setting hydrants, due regard should be given to final grade line.

**A-4-8**

See Figure A-4-8 for sample hydraulic information sign.

**Figure A-4-8 System hydraulic information sign.**

Location of the two hydraulically most remote hose connections: _____
Design flow rate for the connections identified above: _____
Design residual inlet and outlet pressures for the connections identified above: _____
Design static pressure and design system demand (i.e., flow and residual pressure) at the system control valve, or at the pump discharge flange where a pump is installed, and at each fire department connection: _____

**A-5-1**

The building height determines the number of vertical zones. The area of a floor or fire area and exit locations, as well as the occupancy classification, determine the number and locations of hose connections. Local building codes influence types of systems, classes of systems, and locations of hose connections. Pipe sizing is dependent on the number of hose connections flowing, the quantity of water flowed, the required residual pressure, and the vertical and horizontal distance of those hose connections from the water supplies.

For typical elevation drawings, see Figures A-5-1(a), A-5-1(b), and A-5-1(c).

**Figure A-5-1(a) Typical single-zone system.**

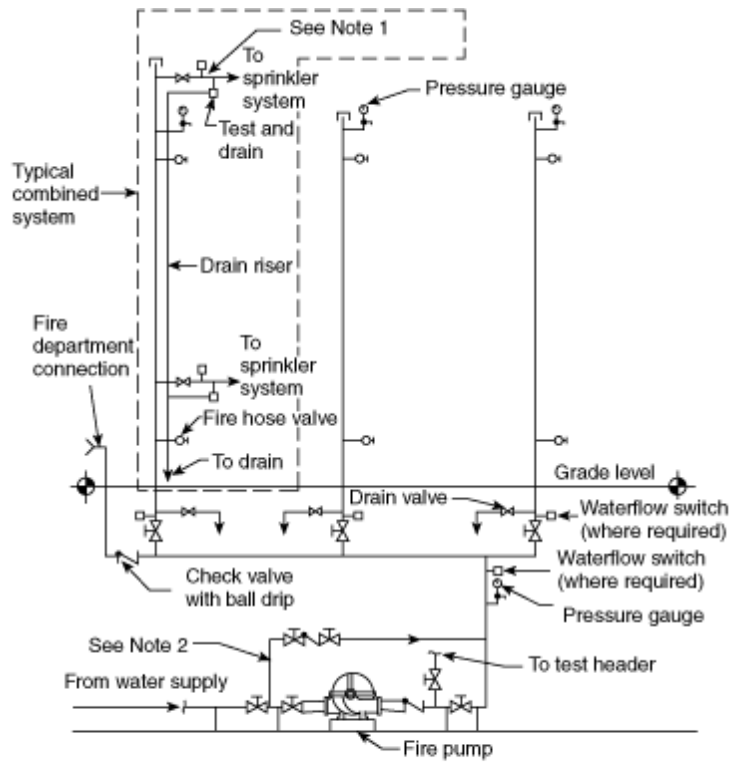

- Notes:
1. Sprinkler floor assembly in accordance with NFPA 13, *Standard for the Installation of Sprinkler Systems*.
  2. Bypass in accordance with NFPA 20, *Standard for the Installation of Stationary Pumps for Fire Protection*.

**Figure A-5-1(b) Typical two-zone system.**

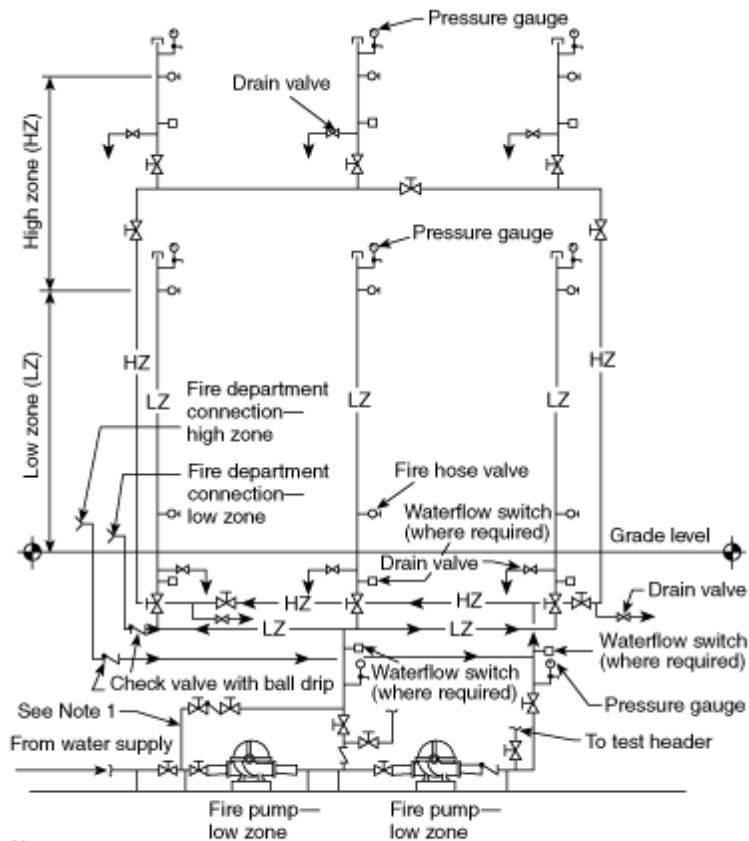

- Notes:
1. Bypass in accordance with NFPA 20, *Standard for the Installation of Stationary Pumps for Fire Protection*.
  2. High zone pump can be arranged to take suction directly from source of supply.

**Figure A-5-1(c) Typical multizone system.**

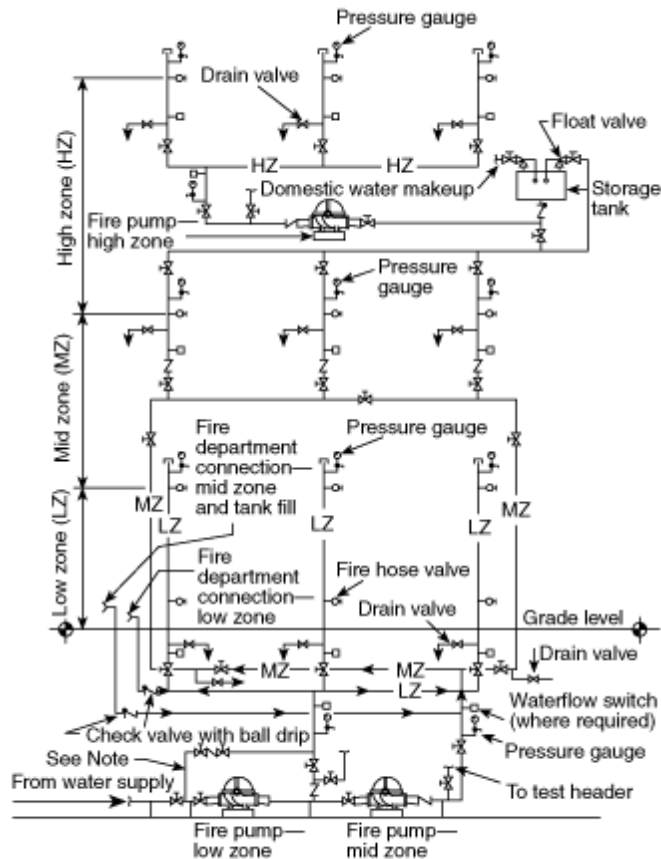

Note: Bypass in accordance with NFPA 20, *Standard for the Installation of Stationary Pumps for Fire Protection*.

## A-5-2

The system pressure limits have been implemented to replace the former height units. Because the issue addressed by the height limits has always been maximum pressure, pressure limitations are a more direct method of regulation and allow flexibility in height units where pumps are used, because a pump curve with less excess pressure at churn yields lower maximum system pressures while achieving the required system demand.

The maximum system pressure normally is at pump churn. The measurement should include both the pump boost and city static pressures. The 350-psi (24-bar) limit was selected because it is the maximum pressure at which most system components are available, and it recognizes the need for a reasonable pressure unit.

### A-5-3.1

Hose can be permitted to be located at one side of the standpipe and supplied by short lateral connections to the standpipe where necessary to avoid obstructions.

Hose connections for Class I systems should be located in a stairway enclosure, and connections for Class II systems should be located in the corridor or space adjacent to the stairway enclosure and connected through the wall to the standpipe. For Class III systems, the connections for 2½-in. (63.5-mm) hose should be located in a stairway enclosure, and Class II connections should be located in the corridor or space adjacent to the stairway enclosure. These arrangements make it possible to use Class II system hose streams promptly in case the stairway is filled with people who are escaping at the time of fire. In buildings having large areas, connections for Class I and Class III systems can be located at interior columns.

### A-5-3.2

Hose connections are now specified to be located at intermediate landings between floors to prevent congestion at

doorways. Where there are multiple intermediate floor landings between floors, hose connections should be located at the landing approximately midway between floors. It is recognized that fire departments often use the hose connection on the floor below the fire floor, and the location of hose connections at intermediate landings also reduces the hose lay distance in such cases.

The approach to locating hose connections with respect to exits is shown in Figures A-5-3.2(a), A-5-3.2(b), and A-5-3.2(c).

**Figure A-5-3.2(a) Location of hose connections in stairwells.**

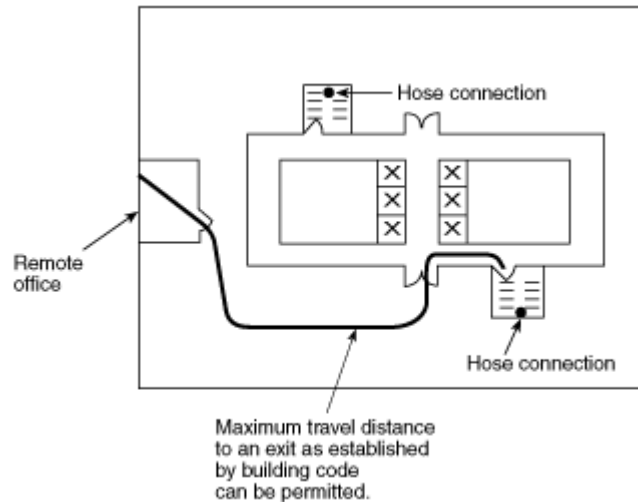

**Figure A-5-3.2(b) Location of hose connections at horizontal exits.**

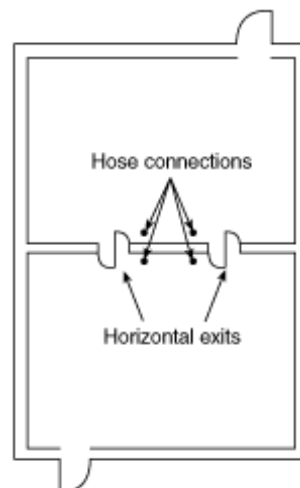

**Figure A-5-3.2(c) Location of hose connections in exit passageways.**

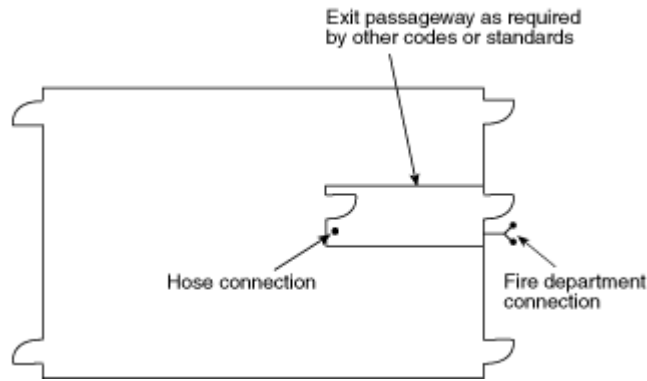

For the purposes of this standard, the following terms are defined for use in locating hose connections.

*Exit Passageways.* Hallways, corridors, passages, or tunnels used as exit components and separated from other parts of the building in accordance with NFPA 101®, *Life Safety Code*®.

*Horizontal Exit.* A way of passage from an area in one building to an area in another building on approximately the same level, or a way of passage through or around a fire barrier from one area to another on approximately the same level in the same building that affords safety from fire and smoke originating from the area of incidence and areas communicating therewith.

### **A-5-3.2(f)**

Paragraph 5-3.2(f) is intended to provide local fire departments with the authority to require additional hose connections outside of or away from a 2-hour fire-resistive separation. These additional hose connections could be needed to allow fire fighters to attach a fire in a reasonable time frame, based on the lengths of hose available on fire department standpipe packs or in carry bags. While it is recognized that outlet spacing limitations provide controls to limit the maximum hose length needed to fight a fire, thereby minimizing the physical demands on fire fighters, it is also recognized that, in some cases, based on architectural layout, additional outlets could be needed in open floor areas in order to meet spacing requirements. In such cases, it is unlikely that such outlets could be utilized, since there would not be a staging area for fire fighters to use when accessing the hose connection. Therefore, additional hose connections, where provided to meet distance requirements, would be located in 1-hour fire-resistive exit corridors wherever possible to provide a degree of protection for fire fighters accessing the connection. Such connections also should be located as uniformly as possible from floor to floor so that fire fighters can find them easily during a fire.

It is recognized that the 200-ft (61-m) distance allowed for sprinklered buildings could necessitate additional hose lengths in order to reach the most remote portion of a floor; however, automatic sprinklers should provide adequate control to allow time for fire fighters to extend hoses in those cases where a fire is located in the most remote area.

### **A-5-3.3**

Hose stations should be so arranged as to allow discharge to be directed from the nozzle into all portions of important enclosures such as closets and similar enclosures.

### **A-5-5**

Fire department connections feeding interconnected standpipes, including combined systems, should be arranged to supply all interconnected standpipes in a building or section of a building. See Figures A-5-1(a), A-5-1(b), and A-5-1(c).

### **A-5-7**

Where determining the pressure at the outlet of the remote hose connection, the pressure loss in the hose valve should be considered.

It is very important that fire departments choose an appropriate nozzle type for their standpipe fire-fighting

operations. Constant pressure- (automatic-) type spray nozzles [see NFPA 1964, *Standard for Spray Nozzles (Shutoff and Tip)*] should not be used for standpipe operations because many of this type require a minimum of 100 psi (6.9 bar) of pressure at the nozzle inlet to produce a reasonably effective fire stream. In standpipe operations, hose friction loss could prevent the delivery of 100 psi (6.9 bar) to the nozzle.

In high-rise standpipe systems with pressure-reducing hose valves, the fire department has little or no control over hose valve outlet pressure.

Many fire departments use combination (fog and straight stream) nozzles requiring 100-psi (6.9-bar) residual pressure at the nozzle inlet with 1½-in., 1¾-in., or 2-in. (38.1-mm, 44.5-mm, or 51-mm) hose in lengths of up to 150 ft (45.7 m). Some use 2½-in. (63.5-mm) hose with a smoothbore nozzle or a combination nozzle.

The 2½-in. (63.5-mm) smoothbore nozzle with a 1⅛-in. (28.6-mm) tip produces a usable stream [250 gpm (946 L/min)] at 50-psi (3.5-bar) inlet pressure requiring 65 psi (4.5 bar) at the valve outlet with 100 ft (30.5 m) of 2½-in. (63.5-mm) hose or 73 psi (5 bar) at the outlet with 150 ft (45.7 m) of hose.

Some departments use 50 ft (15.2 m) of 2½-in. (63.5-mm) hose to a gated wye, supplying two 100-ft (30.5-m) lengths of 1½-in. to 2-in. (38.1-mm to 51-mm) hose with combination nozzles, requiring 120 psi to 149 psi (8.3 bar to 10.3 bar) at the valve outlet. (See Table A-5-7.)

Also see NFPA 1901, *Standard for Automotive Fire Apparatus*.

## A-5-8

Due to the different pressure limitations established in Section 5-8, it could be necessary to arrange piping so that separate pressure-regulating devices can be provided on the Class I and Class II hose connections.

### A-5-8.2

Many fire departments lay a hoseline from the pumper into the building and connect to an accessible valve outlet using a double female swivel where the building fire department connections are inaccessible or inoperable. To pressurize the standpipe, the hose valve is opened and the engine pumps into the system.

If the standpipe is equipped with pressure-reducing hose valves, the valve acts as a check valve, prohibiting pumping into the system when the valve is open.

A supplementary single-inlet fire department connection or hose valve with female threads at an accessible location on the standpipe allows pumping into that system.

### A-5-9.1.1

If a water supply system supplies more than one building or more than one fire area, the total supply can be calculated based on the single building or fire area requiring the greatest number of standpipes.

**Table A-5-7 Hose Stream Friction Losses Summary**

Calc. No.	Nozzle/Hose	Flow		Valve Outlet	
		gpm	L/min	psi	bar
1	2½-in. (63.5-mm) combination nozzle, with 150 ft (45.7 m) of 2½-in. (63.5-mm) hose	250	946	123	8.5

Calc. No.	Nozzle/Hose	Flow		Valve Outlet	
		gpm	L/min	psi	bar
2	2 <sup>1</sup> / <sub>2</sub> -in. (63.5-mm) smoothbore nozzle with 1 <sup>1</sup> / <sub>8</sub> -in. (28.6-mm) tip and 150 ft (45.7 m) of 2 <sup>1</sup> / <sub>2</sub> -in. (63.5-mm) hose	250	946	73	5
3	Two 1 <sup>1</sup> / <sub>2</sub> -in. (38.1-mm) combination nozzles with 100 ft (30.5 m) of 1 <sup>1</sup> / <sub>2</sub> -in. (38.1-mm) hose per nozzle, 2 <sup>1</sup> / <sub>2</sub> -in. (63.5-mm) gated wye, and 50 ft (15.2 m) of 2 <sup>1</sup> / <sub>2</sub> -in. (63.5-mm) hose	250	946	149	10.3
4	Same as calculation no. 3 with two 100-ft (30.5-m) lengths of 1 <sup>3</sup> / <sub>4</sub> -in. 44.5-mm hose	250	946	139	9.6
5	Same as calculation no. 3 with two 100-ft (30.5-m) lengths of 2-in. (51-mm) hose	250	946	120	8.3
6	1 <sup>1</sup> / <sub>2</sub> -in. (38.1-mm) combination nozzle with 150 ft (45.7 m) of 2-in. (51-mm) hose	200	757	136	9.4
7	Same as calculation no. 6 with 1 <sup>3</sup> / <sub>4</sub> -in. (44.5-mm) hose	200	757	168	11.6

For a discussion of use by the fire department of fire department connections, see NFPA 13E, *Guide for Fire Department Operations in Properties Protected by Sprinkler and Standpipe Systems*.

### A-5-9.1.2

See Section 6-4 of NFPA 13, *Standard for the Installation of Sprinkler Systems*.

#### A-5-9.1.3.1

The following list provides occupancy examples according to various hazard classifications. These examples are intended to represent the norm for those occupancy types. Unusual or abnormal fuel loadings or combustible characteristics and susceptibility to changes in these characteristics for a particular occupancy should be considered in selection and classification.

The light hazard classification is intended to encompass residential occupancies; however, it does not preclude the use of listed residential sprinklers in residential occupancies or residential portions of other occupancies.

(a) Light hazard occupancies include occupancies having conditions similar to the following:

- (1) Churches
- (2) Clubs
- (3) Eaves and overhangs, if of combustible construction with no combustibles beneath
- (4) Educational
- (5) Hospitals
- (6) Institutional

- (7) Libraries, except large stack rooms
- (8) Museums
- (9) Nursing or convalescent homes
- (10) Offices, including data processing areas
- (11) Residential
- (12) Restaurant seating areas
- (13) Theaters and auditoriums, excluding stages and prosceniums
- (14) Unused attics

(b) Ordinary hazard (Group 1) occupancies include occupancies having conditions similar to the following:

- (1) Automobile parking and showrooms
- (2) Bakeries
- (3) Beverage manufacturing
- (4) Canneries
- (5) Dairy products manufacturing and processing
- (6) Electronic plants
- (7) Glass and glass products manufacturing
- (8) Laundries
- (9) Restaurant service areas

(c) Ordinary hazard (Group 2) occupancies include occupancies having conditions similar to the following:

- (1) Cereal mills
- (2) Chemical plants (ordinary)
- (3) Confectionery products manufacturing
- (4) Distilleries
- (5) Dry cleaners
- (6) Feed mills
- (7) Horse stables
- (8) Leather goods manufacturing
- (9) Libraries (large stack room areas)
- (10) Machine shops
- (11) Metalworking
- (12) Mercantile
- (13) Paper and pulp mills
- (14) Paper process plants
- (15) Piers and wharves
- (16) Post offices
- (17) Printing and publishing
- (18) Repair garages



(19) Stages

(20) Textile manufacturing

(21) Tire manufacturing

(22) Tobacco products manufacturing

(23) Wood machining

(24) Wood product assembly

(d) Extra hazard (Group 1) occupancies include occupancies having conditions similar to the following:

(1) Aircraft hangars

(2) Combustible hydraulic fluid use areas

(3) Die casting

(4) Metal extruding

(5) Plywood and particle board manufacturing

(6) Printing [using inks having flash points below 100°F (37.9°C)]

(7) Rubber reclaiming, compounding, drying, milling, and vulcanizing

(8) Sawmills

(9) Textile picking, opening, blending, garnetting, and carding; combining of cotton, synthetics, wool shoddy, or burlap

(10) Upholstering with plastic foams

(e) Extra hazard (Group 2) occupancies include occupancies having conditions similar to the following:

(1) Asphalt saturating

(2) Flammable liquids spraying

(3) Flow coating

(4) Mobile home or modular building assemblies (where finished enclosure is present and has combustible interiors)

(5) Open oil quenching

(6) Plastics processing

(7) Solvent cleaning

(8) Varnish and paint dipping

See Figures A-5-9.1.3.1(a) and A-5-9.1.3.1(b).

**Figure A-5-9.1.3.1(a) Acceptable piping arrangement for combined sprinkler/standpipe systems.**

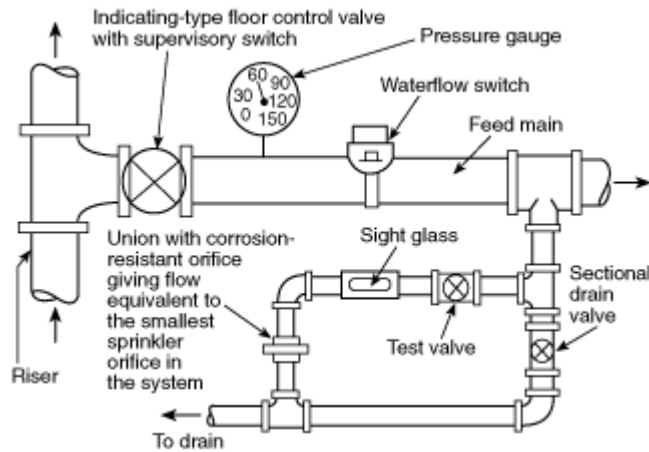

**Figure A-5-9.1.3.1(b) Acceptable piping arrangement for combined sprinkler/standpipe systems.**

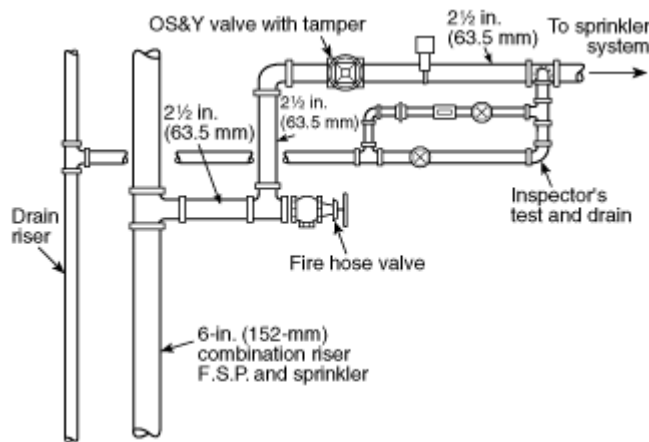

### A-5-11

During flow testing of pressure-reducing valves, care should be taken in making connections to drain risers. An air gap should be maintained in order to prevent cross connection to nonpotable water sources.

### A-5-12

See NFPA 13E, *Guide for Fire Department Operations in Properties Protected by Sprinkler and Standpipe Systems*.

The number of 2½-in. (63.5-mm) inlets to supply the required water volume and pressure at the fire department connection is dependent on several variables such as the performance of the water supply at the source, the distance from the source to the location of the inlets, the diameter of the hose used, the size of the fire department pumper, and the required water volume and pressure at the base of the standpipe riser(s).

### A-5-13.1

Fire department pumpers will normally be required to augment the pressure available from public hydrants.

### A-5-13.2

With use of wall hydrants, the authority having jurisdiction should be consulted regarding the necessary water supply and arrangement of control valves at the point of supply in each individual case. (See Figure A-5-13.2.)

**Figure A-5-13.2 Typical wall fire hydrant installation.**

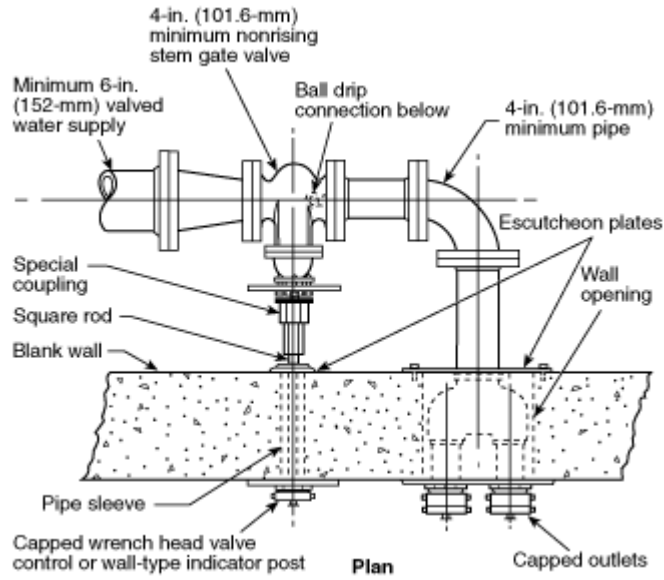

**A-5-15**

For typical master stream devices, see Figures A-5-15(a) and A-5-15(b).

**Figure A-5-15(a) Standard monitor nozzles. (Gear control nozzles are also satisfactory.)**

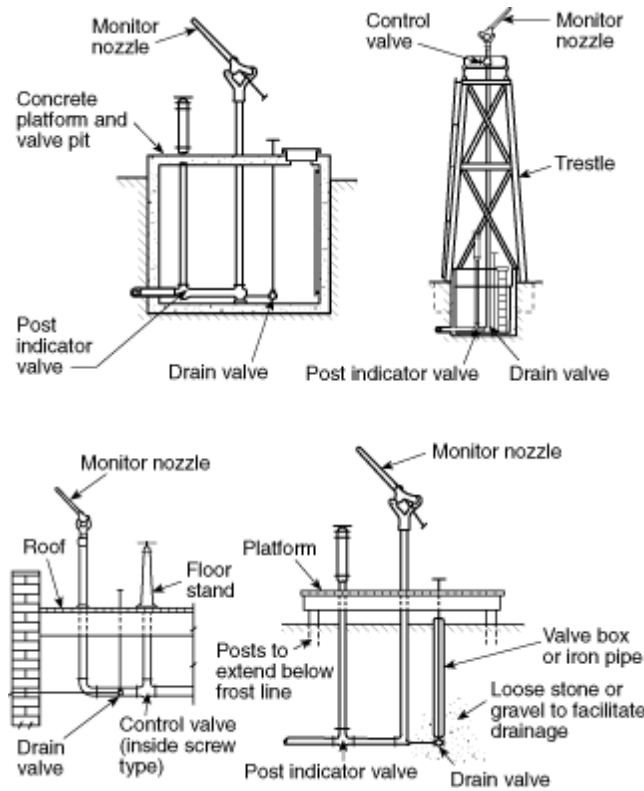

**Figure A-5-15(b) Typical hydrant-mounted monitor nozzle.**



#### **A-6-1**

Plans should indicate the type of fire department equipment that the system is designed to serve, including the hose size, hose length, and hose nozzle. Such equipment is the basis for the pressure selected in accordance with Section 5-7.

#### **A-7-1**

The selection of water supplies for each installation should be determined in cooperation with the authority having jurisdiction.

##### **A-7-1.2**

See NFPA 20, *Standard for the Installation of Stationary Pumps for Fire Protection*, and NFPA 22, *Standard for Water Tanks for Private Fire Protection*.

#### **A-8-1**

Additional benefit is derived from waterflow tests by the indication of possible deficiencies, such as tuberculation of piping, closed valves, or other obstructions, which should be corrected to provide adequate waterflows.

#### **A-9-1**

Where standpipe connections are built into the walls or partitions, the hydrostatic tests should be made before they are covered or permanently sealed.

*Example of Required Hydrostatic Test Pressure.* The water supply for a standpipe system is the connection to a public water service main. A 100-psi (6.9-bar) rated pump is installed in the connection. With a maximum normal public water supply pressure of 70 psi (4.9 bar) at the low elevation point of the system or zone being tested and a 120-psi (8.3-bar) pump (churn) pressure, the hydrostatic test pressure is 70 psi + 120 psi + 50 psi, or 240 psi (16.6 bar). (See NFPA 24, *Standard for the Installation of Private Fire Service Mains and Their Appurtenances*, for permitted leakage in underground piping.)

##### **A-9-4.1**

The testing and flushing of the underground pipe should be in accordance with NFPA 24, *Standard for the Installation of Private Fire Service Mains and Their Appurtenances*.

### **A-9-5.1**

The hydraulically most remote hose connections in a building are generally at a roof manifold, if provided, or at the top of a stair leading to the roof. In a multizone system, the testing means is generally at a test header at grade or at a suction tank on higher floors.

Where a flow test at the hydraulically most remote hose connection is not practicable, the authority having jurisdiction should be consulted for the appropriate location of the test.

### **A-10-5**

There should be a substantial box, preferably of metal, located at the highest hose connection, in which a quantity of hose sufficient to reach all parts of the floor, a 1<sup>1</sup>/<sub>8</sub> -in. (29-mm) nozzle, spanner wrenches, and hose straps should be kept.

### **A-10-6**

Top hose connections should not be located more than one floor below the highest forms, staging, and similar combustibles at any time.

## **Appendix B Fire Flow Test Procedure**

*This appendix is not a part of the requirements of this NFPA document but is included for informational purposes only.*

### **B-1 Test Method.**

#### **B-1.1**

After the location where the test is to be conducted has been determined, a group of test hydrants in the vicinity is selected. Once selected, due consideration is given to potential interference with traffic flow patterns, damage to surroundings (e.g., roadways, sidewalks, landscapes, vehicles, and pedestrians), and potential flooding problems both local and remote from the test site. One hydrant, designated the residual hydrant, is chosen to be the hydrant where the normal static pressure will be observed with the other hydrants in the group closed, and where the residual pressure will be observed with the other hydrants flowing. This hydrant is chosen so it will be located between the hydrant to be flowed and the large mains that constitute the immediate sources of water supply in the area. In Figure B-1.1, test layouts are indicated showing the residual hydrant designated with *R* and hydrants to be flowed with the letter *F*. The number of hydrants to be used in any test depends upon the strength of the distribution system in the vicinity of the test location. To obtain satisfactory test results of theoretical calculation of expected flows or rated capacities, sufficient discharge should be achieved to cause a drop in pressure at the residual hydrant of at least 25 percent, or to flow the total demand necessary for the system demand or fire-fighting purposes.

**Figure B-1.1 Suggested flow test layouts.**

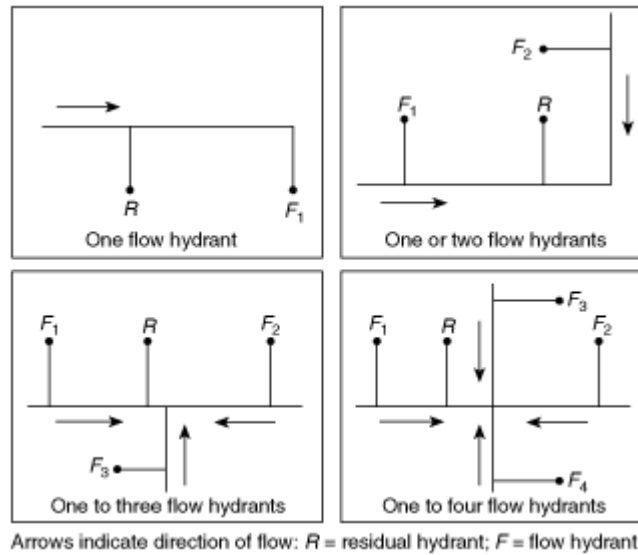

## B-1.2

If the mains are small and the system weak, only one or two hydrants need to be flowed. If, on the other hand, the mains are large and the system strong, it can be necessary to flow as many as seven or eight hydrants.

It is preferable to flow water past the residual hydrant.

## B-2 Equipment.

### B-2.1

The equipment necessary for field work consists of a single 200-psi (14-bar) bourdon pressure gauge with 2-psi (0.1378-bar) graduations, a number of Pitot tubes, hydrant wrenches, 50- or 60-psi (3.5- or 4.0-bar) bourdon pressure gauges with 1-psi (0.0689-bar) graduations, and scales with  $\frac{1}{16}$ -in. (1.6-mm) graduations [one Pitot tube, a 50- or 60-psi (3.5- or 4.0-bar) gauge, a hydrant wrench, and a scale for each hydrant to be flowed], and a special hydrant cap tapped with a hole into which a short length of  $\frac{1}{4}$ -in. (6.35-mm) brass pipe is fitted. This pipe is provided with a T connection for the 200-psi (14-bar) gauge and a cock at the end for relieving air pressure. All pressure gauges should be calibrated at least every 12 months or more frequently depending on use.

### B-2.2

When more than one hydrant is flowed, it can be desirable and necessary to use portable radios to facilitate communications. It is preferred to use an Underwriter's Playpipe, or other stream straightener, with a known coefficient of discharge, when testing hydrants due to a more streamlined flow and more accurate Pitot reading.

## B-3 Test Procedure.

### B-3.1

In a typical test, the 200-psi (14-bar) gauge is attached to one of the  $2\frac{1}{2}$ -in. (64-mm) outlets of the residual hydrant using the special cap, the cock on the gauge piping is opened, and the hydrant valve is opened full. As soon as the air is exhausted from the barrel, the cock is closed. A reading (static pressure) is taken when the needle comes to rest. At a given signal each of the other hydrants is opened in succession, with discharge taking place directly from the open hydrant butts. Hydrants should be opened one at a time. With all hydrants flowing, water should be allowed to flow for a sufficient time to clear all debris and foreign substances from the stream(s). At that time, a signal is given to the people at the hydrants to read the Pitot pressure of the streams simultaneously while the residual pressure is being read. The final magnitude of the pressure drop can be controlled by the number of hydrants used and the number of outlets opened on each.

### B-3.2

After the readings have been taken, hydrants should be shut down slowly, one at a time, to prevent undue surges in the system.

## B-4 Pitot Readings.

### B-4.1

When measuring discharge from open hydrant butts, 2½-in. (64-mm) outlets rather than pumper outlets should be used.

### B-4.2

In practically all cases, the 2½-in. (64-mm) outlets are filled across the entire cross section during flow, while in the case of the larger outlets there is very frequently a void near the bottom. When measuring the Pitot pressure of a stream of practically uniform velocity, the orifice in the Pitot tube is held downstream approximately one-half the diameter of the hydrant outlet or nozzle opening, and in the center of the stream. The centerline of the orifice should be at right angles to the plane of the face of the hydrant outlet. The air chamber on the Pitot tube should be kept elevated. Pitot readings of less than 10 psi (0.7 bar) and more than 30 psi (2.0 bar) should be avoided, if possible. Opening additional hydrant outlets will aid in controlling the Pitot reading. With dry barrel hydrants, the hydrant valve should be wide open. This minimizes problems with underground drain valves. With wet barrel hydrants, the valve for the flowing outlet should be wide open. This opening gives a more streamlined flow and a more accurate Pitot reading. (See Figure B-4.2.)

**Figure B-4.2 Pitot tube position.**

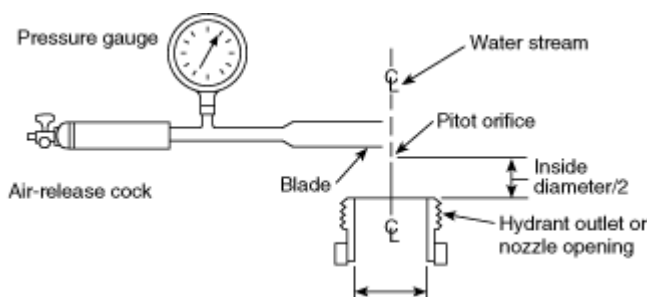

## B-5 Determination of Discharge.

At the hydrants used for flow during the test, the discharges from the open butts should be determined from measurements of the diameter of the outlets flowed, the Pitot pressure (velocity head) of the streams as indicated by the Pitot gauge readings, and the coefficient of the outlet being flowed as determined from Figure B-5. If flow tubes (stream straighteners) are being utilized, a coefficient of 0.95 is used unless the coefficient of the tube is known.

The formula used to compute the discharge,  $Q$ , in gpm from these measurements is

$$Q = 29.83 cd^2 \sqrt{P}$$

Where

$c$  = coefficient of discharge (see Figure B-5)

$d$  = diameter of the outlet (in.)

$P$  = Pitot pressure (velocity head) (psi)

**Figure B-5 Three general types of hydrant outlets and their coefficients of discharge.**

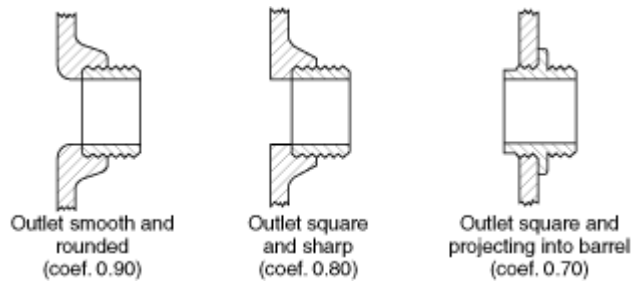

## B-6 Use of Pumper Outlets.

If it is necessary to use a pumper outlet, and flow tubes (stream straighteners) are not available, the best results are obtained with the Pitot pressure (velocity head) maintained between 5 psi and 10 psi (0.3 bar and 0.7 bar). For pumper outlets, the approximate discharge can be computed from Equation B.1 using the Pitot pressure (velocity head) at the center of the stream and multiplying the result by one of the coefficients in Table B-6, depending upon the Pitot pressure (velocity head). These coefficients are applied in addition to the coefficient in Equation B.1 and are for average type hydrants.

**Table B-6 Pumper Outlet Coefficients**

Pitot Pressure (Velocity Head)		Coefficient
psi	bar	
2	0.14	0.97
3	0.21	0.92
4	0.28	0.89
5	0.35	0.86
6	0.41	0.84
7 and over	0.48 and over	0.83

## B-7 Determination of Discharge Without a Pitot.

If a Pitot tube is not available for use to measure the hydrant discharge, a 50- or 60-psi (3.5- or 4.0-bar) gauge tapped into a hydrant cap can be used. The hydrant cap with gauge attached is placed on one outlet, and the flow is allowed to take place through the other outlet at the same elevation. The readings obtained from a gauge so located, and the readings obtained from a gauge on a Pitot tube held in the stream, are approximately the same.

## B-8 Calculation Results.

### B-8.1 Discharge Calculations from Formula.

The discharge in gpm (L/min) for each outlet flowed is obtained from the discharge tables in Table B-8.1 or by the use of Equation B.2. If more than one outlet is used, the discharges from all are added to obtain the total discharge.

The formula that is generally used to compute the discharge at the specified residual pressure or for any desired pressure drop is Equation B.2:

$$Q_R = Q_F \times \frac{h_r^{0.54}}{h_f^{0.54}} \quad (\text{B.2})$$

Where

$Q_R$  = flow predicted at desired residual pressure

$Q_F$  = total flow measured during test

$h_r$  = pressure drop to desired residual pressure



$h_j$  = pressure drop measured during test

In this equation, any units of discharge or pressure drop can be used as long as the same units are used for each value of the same variable. In other words, if  $Q_R$  is expressed in gpm,  $Q_F$  must be in gpm, and if  $h_r$  is expressed in psi,  $h_j$  must be expressed in psi. These are the units that are normally used in applying Equation B.2 to fire flow test computations.

### B-8.2 Discharge Calculations from Table B-8.2.

One means of solving this equation without the use of logarithms is by using Table B-8.2. This table gives the values of the 0.54 power of the numbers from 1 to 175. Knowing the values of  $h_j$ ,  $h_r$ , and  $Q_F$ , the values of  $h_j^{0.54}$  and  $h_r^{0.54}$  can be read from the table and Equation B.2 solved for  $Q_R$ . Results are usually carried to the nearest 100 gpm (380 L/min) for discharges of 1000 gpm (3800 L/min) or more, and to the nearest 50 gpm (190 L/min) for smaller discharges, which is as close as can be justified by the degree of accuracy of the field observations.

The method of use for Table B-8.2 is as follows — insert the values of  $h_r^{0.54}$  and  $h_j^{0.54}$  determined from the table and the value of  $Q_F$  in Equation B.2, and solve the equation of  $Q_R$ .

### B-9 Data Sheet.

The data secured during the testing of hydrants for uniform marking can be valuable for other purposes. With this in mind, it is suggested that the form shown in Figure B-9 be used to record information that is taken. The back of the form should include a location sketch. When the tests are complete, the forms should be filed for future reference by interested parties.

**Table B-8.1 Theoretical Discharge Through Circular Orifices (U.S. Gallons of Water per Minute)**

Pitot Pressure psi <sup>a</sup> (kPa)	Ft <sup>b</sup> (m)	Velocity Discharge ft/sec (m/sec)	Orifice Diameter							
			2 (51)	2 <sup>1</sup> / <sub>4</sub> (57)	2 <sup>3</sup> / <sub>8</sub> (60)	2 <sup>1</sup> / <sub>2</sub> (64)	2 <sup>5</sup> / <sub>8</sub> (67)	2 <sup>3</sup> / <sub>4</sub> (70)	3 (76)	3 <sup>1</sup> / <sub>4</sub> (83)
1 (6.89)	2.31 (0.70)	12.20 (3.72)	119 (451)	151 (571)	168 (637)	187 (705)	206 (778)	226 (854)	269 (1020)	315 (1190)
2 (13.8)	4.61 (1.41)	17.25 (5.26)	169 (639)	214 (808)	238 (900)	264 (1000)	291 (1100)	319 (1210)	380 (1440)	446 (1690)
3 (20.7)	6.92 (2.11)	21.13 (6.44)	207 (782)	262 (990)	292 (1100)	323 (1220)	356 (1350)	391 (1480)	465 (1760)	546 (2070)
4 (27.6)	9.23 (2.81)	24.39 (7.43)	239 (930)	302 (1140)	337 (1280)	373 (1410)	411 (1560)	452 (1710)	537 (2030)	631 (2390)
5 (34.5)	11.54 (3.52)	27.26 (8.31)	267 (1010)	338 (1280)	376 (1420)	417 (1580)	460 (1740)	505 (1910)	601 (2270)	705 (2670)
6 (41.4)	13.84 (4.22)	29.87 (9.10)	292 (1110)	370 (1400)	412 (1560)	457 (1730)	504 (1910)	553 (2090)	658 (2490)	772 (2920)
7 (48.3)	16.15 (4.92)	32.26 (9.83)	316 (1190)	400 (1510)	445 (1680)	494 (1870)	544 (2060)	597 (2260)	711 (2690)	834 (3160)
8 (55.2)	18.46 (5.63)	34.49 (10.51)	338 (1280)	427 (1620)	476 (1800)	528 (2000)	582 (2200)	638 (2410)	760 (2880)	892 (3380)
9 (62.0)	20.76 (6.33)	36.58 (11.15)	358 (1360)	453 (1710)	505 (1910)	560 (2120)	617 (2340)	677 (2560)	806 (3050)	946 (3580)
10 (68.9)	23.07 (7.03)	38.56 (11.75)	378 (1430)	478 (1810)	532 (2010)	590 (2230)	650 (2460)	714 (2700)	850 (3220)	997 (3770)
11 (75.8)	25.38 (7.73)	40.45 (12.33)	396 (1500)	501 (1900)	553 (2110)	619 (2340)	682 (2580)	759 (2830)	891 (3370)	1046 (3960)
12 (82.7)	27.68 (8.44)	42.24 (12.87)	414 (1560)	524 (1980)	583 (2210)	646 (2450)	712 (2690)	782 (2960)	931 (3520)	1092 (4130)

Pitot Pressure psi <sup>a</sup> (kPa)	Ft <sup>b</sup> (m)	Velocity Discharge ft/sec (m/sec)	Orifice Diameter							
			2	2 <sup>1</sup> / <sub>4</sub>	2 <sup>3</sup> / <sub>8</sub>	2 <sup>1</sup> / <sub>2</sub>	2 <sup>5</sup> / <sub>8</sub>	2 <sup>3</sup> / <sub>4</sub>	3	3 <sup>1</sup> / <sub>4</sub>
			(51)	(57)	(60)	(64)	(67)	(70)	(76)	(83)
13	29.99	43.97	431	545	607	673	741	814	969	1137
(89.6)	(9.14)	(13.40)	(1630)	(2060)	(2300)	(2550)	(2800)	(3080)	(3670)	(4300)
14	32.30	45.63	447	566	630	698	769	845	1005	1180
(96.5)	(9.84)	(13.91)	(1690)	(2140)	(2380)	(2640)	(2910)	(3200)	(3800)	(4470)
15	34.61	47.22	463	586	652	722	796	874	1040	1221
(103)	(10.55)	(14.39)	(1750)	(2220)	(2470)	(2730)	(3010)	(3310)	(3940)	(4620)
16	36.91	48.78	478	605	673	746	822	903	1075	1261
(110)	(11.25)	(14.87)	(1810)	(2290)	(2550)	(2820)	(3110)	(3420)	(4070)	(4770)
17	39.22	50.28	493	623	694	769	848	931	1108	1300
(117)	(11.95)	(15.33)	(1870)	(2360)	(2630)	(2910)	(3210)	(3520)	(4190)	(4920)
18	41.53	51.73	507	642	714	791	872	958	1140	1338
(124)	(12.66)	(15.77)	(1920)	(2430)	(2700)	(2990)	(3300)	(3630)	(4310)	(5060)
19	43.83	53.15	521	659	733	813	896	984	1171	1374
(131)	(13.36)	(16.20)	(1970)	(2490)	(2770)	(3080)	(3390)	(3720)	(4430)	(5200)
20	46.14	54.54	534	676	753	834	920	1010	1201	1410
(138)	(14.06)	(16.62)	(2020)	(2560)	(2850)	(3160)	(3480)	(3820)	(4540)	(5330)
22	50.75	57.19	560	709	789	875	964	1059	1260	1479
(152)	(15.47)	(17.43)	(2120)	(2680)	(2990)	(3310)	(3650)	(4000)	(4770)	(5590)
24	55.37	59.74	585	741	824	914	1007	1106	1316	1545
(165)	(16.88)	(18.21)	(2210)	(2800)	(3120)	(3460)	(3810)	(4180)	(4980)	(5840)
26	59.98	62.18	609	771	858	951	1048	1151	1370	1608
(179)	(18.28)	(18.95)	(2300)	(2910)	(3250)	(3600)	(3970)	(4350)	(5180)	(6080)
28	64.60	64.52	632	800	890	987	1088	1194	1422	1668
(193)	(19.69)	(19.67)	(2390)	(3020)	(3370)	(3730)	(4120)	(4520)	(5380)	(6310)
30	69.21	66.79	654	828	922	1022	1126	1236	1472	1727
(207)	(21.10)	(20.36)	(2470)	(3130)	(3490)	(3860)	(4260)	(4680)	(5570)	(6530)
32	73.82	68.9	676	856	952	1055	1163	1277	1520	1784
(221)	(22.50)	(21.03)	(2550)	(3230)	(3600)	(3990)	(4400)	(4830)	(5750)	(6750)
34	78.44	71.10	697	882	981	1088	1199	1316	1566	1838
(234)	(23.91)	(21.67)	(2640)	(3340)	(3710)	(4120)	(4540)	(4980)	(5930)	(6960)
36	83.05	73.16	717	908	1010	1119	1233	1354	1612	1892
(248)	(25.31)	(22.30)	(2710)	(3440)	(3820)	(4240)	(4670)	(5120)	(6100)	(7160)
38	87.67	75.17	736	932	1037	1150	1267	1392	1656	1944
(262)	(26.72)	(22.91)	(2790)	(3530)	(3930)	(4350)	(4800)	(5270)	(6270)	(7360)
40	92.28	77.11	755	956	1064	1180	1300	1428	1699	1994
(276)	(28.13)	(23.50)	(2860)	(3620)	(4030)	(4470)	(4920)	(5400)	(6430)	(7550)
42	96.89	79.03	774	980	1091	1209	1332	1463	1741	2043
(290)	(29.53)	(24.09)	(2930)	(3710)	(4130)	(4580)	(5040)	(5540)	(6590)	(7730)
44	101.51	80.88	792	1003	1116	1237	1364	1497	1782	2091
(303)	(30.94)	(24.65)	(3000)	(3800)	(4220)	(4680)	(5160)	(5670)	(6740)	(7910)
46	106.12	82.70	810	1025	1141	1265	1394	1531	1822	2138
(317)	(32.35)	(25.21)	(3070)	(3880)	(4320)	(4790)	(5280)	(5790)	(6900)	(8090)
48	110.74	84.48	828	1047	1166	1293	1424	1564	1861	2184
(331)	(33.75)	(25.75)	(3130)	(3960)	(4410)	(4890)	(5390)	(5920)	(7040)	(8270)
50	115.35	86.22	845	1069	1190	1319	1454	1596	1900	2229
(345)	(35.16)	(26.28)	(3200)	(4050)	(4500)	(4990)	(5500)	(6040)	(7190)	(8440)
52	119.96	87.93	861	1091	1213	1345	1482	1628	1937	2274
(358)	(36.57)	(26.80)	(3260)	(4130)	(4590)	(5090)	(5610)	(6160)	(7330)	(8610)
54	124.58	89.61	878	1111	1237	1371	1511	1659	1974	2317
(372)	(37.97)	(27.31)	(3320)	(4200)	(4680)	(5190)	(5720)	(6280)	(7470)	(8770)
56	129.19	91.20	894	1132	1259	1396	1538	1689	2010	2359
(386)	(39.38)	(27.80)	(3380)	(4280)	(4770)	(5280)	(5820)	(6390)	(7610)	(8930)

Pitot Pressure psi <sup>a</sup> (kPa)	Ft <sup>b</sup> (m)	Velocity Discharge ft/sec (m/sec)	Orifice Diameter							
			2	2 <sup>1</sup> / <sub>4</sub>	2 <sup>3</sup> / <sub>8</sub>	2 <sup>1</sup> / <sub>2</sub>	2 <sup>5</sup> / <sub>8</sub>	2 <sup>3</sup> / <sub>4</sub>	3	3 <sup>1</sup> / <sub>4</sub>
			(51)	(57)	(60)	(64)	(67)	(70)	(76)	(83)
58	133.81	92.87	909	1152	1282	1421	1566	1719	2046	2401
(400)	(40.78)	(28.31)	(3440)	(4350)	(4850)	(5370)	(5920)	(6500)	(7740)	(9080)
60	138.42	94.45	925	1171	1303	1445	1592	1749	2081	2442
(414)	(42.19)	(28.79)	(3500)	(4430)	(4930)	(5460)	(6030)	(6610)	(7870)	(9240)
62	143.03	96.01	941	1191	1325	1470	1619	1777	2115	2483
(427)	(43.60)	(29.26)	(3560)	(4500)	(5010)	(5560)	(6130)	(6720)	(8000)	(9390)
64	147.65	97.55	956	1210	1346	1493	1645	1806	2149	2522
(441)	(45.00)	(29.73)	(3610)	(4570)	(5090)	(5640)	(6220)	(6830)	(8130)	(9540)
66	152.26	99.07	971	1228	1367	1516	1670	1834	2183	2561
(455)	(46.41)	(30.20)	(3670)	(4640)	(5170)	(5730)	(6320)	(6940)	(8260)	(9690)
68	156.88	100.55	985	1247	1388	1539	1695	1862	2215	2600
(469)	(47.82)	(30.65)	(3720)	(4710)	(5250)	(5820)	(6420)	(7040)	(8380)	(9830)
70	161.49	102.03	999	1265	1408	1561	1720	1889	2248	2638
(483)	(49.22)	(31.10)	(3780)	(4780)	(5330)	(5900)	(6510)	(7140)	(8500)	(9980)
72	166.10	103.47	1014	1283	1428	1583	1745	1916	2280	2675
(496)	(50.63)	(31.54)	(3830)	(4850)	(5400)	(5990)	(6600)	(7250)	(8620)	(10120)
74	170.72	104.90	1028	1301	1448	1605	1769	1942	2311	2712
(510)	(52.03)	(31.97)	(3880)	(4920)	(5480)	(6070)	(6690)	(7350)	(8740)	(10260)
76	175.33	106.30	1041	1318	1467	1627	1792	1968	2342	2749
(524)	(53.44)	(32.71)	(3940)	(4980)	(5550)	(6150)	(6780)	(7440)	(8860)	(10400)
78	179.95	107.69	1055	1335	1486	1648	1816	1994	2373	2785
(538)	(54.85)	(32.82)	(3990)	(5050)	(5620)	(6230)	(6870)	(7540)	(8970)	(10530)
80	184.56	109.08	1068	1352	1505	1669	1839	2019	2403	2820
(552)	(56.25)	(33.25)	(4040)	(5110)	(5690)	(6310)	(6960)	(7640)	(9090)	(10670)
82	189.17	110.42	1082	1369	1524	1689	1862	2044	2433	2855
(565)	(57.66)	(33.66)	(4090)	(5180)	(5770)	(6390)	(7040)	(7730)	(9200)	(10800)
84	193.79	111.76	1095	1386	1542	1710	1884	2069	2462	2890
(579)	(59.07)	(34.06)	(4140)	(5240)	(5840)	(6466)	(7130)	(7830)	(9310)	(10930)
86	198.40	113.08	1170	1402	1561	1730	1907	2094	2491	2924
(593)	(60.47)	(34.47)	(4190)	(5300)	(5900)	(6540)	(7210)	(7920)	(9420)	(11070)
88	203.02	114.39	1120	1419	1579	1750	1929	2118	2520	2958
(607)	(61.88)	(34.87)	(4240)	(5360)	(5970)	(6620)	(7300)	(8010)	(9530)	(11190)
90	207.63	115.68	1133	1434	1596	1770	1950	2142	2549	2991
(620)	(63.29)	(35.26)	(4280)	(5420)	(6040)	(6690)	(7380)	(8100)	(9640)	(11310)
92	212.24	116.96	1146	1450	1614	1789	1972	2165	2577	3024
(634)	(64.69)	(35.65)	(4330)	(5480)	(6110)	(6770)	(7460)	(8190)	(9750)	(11440)
94	216.86	118.23	1158	1466	1632	1809	1993	2189	2605	3057
(648)	(66.10)	(36.04)	(4380)	(5540)	(6170)	(6840)	(7540)	(8280)	(9850)	(11560)
96	221.47	119.48	1170	1481	1649	1828	2014	2212	2632	3089
(662)	(67.50)	(36.42)	(4420)	(5600)	(6240)	(6910)	(7620)	(8370)	(9960)	(11680)
98	226.09	120.71	1182	1497	1666	1847	2035	2235	2660	3121
(676)	(68.91)	(36.79)	(4470)	(5660)	(6300)	(6980)	(7700)	(8450)	(10060)	(11810)
100	230.70	121.94	1194	1512	1683	1866	2056	2258	2687	3153
(689)	(70.32)	(37.17)	(4520)	(5720)	(6370)	(7050)	(7780)	(8540)	(10160)	(11930)
102	235.31	123.15	1206	1527	1699	1884	2076	2280	2713	3184
(703)	(71.72)	(37.54)	(4560)	(5770)	(6430)	(7130)	(7860)	(8620)	(10260)	(12040)
104	239.93	124.35	1218	1542	1716	1903	2097	2302	2740	3215
(717)	(73.13)	(37.90)	(4610)	(5830)	(6490)	(7190)	(7930)	(8710)	(10360)	(12160)
106	244.54	125.55	1230	1556	1733	1921	2117	2324	2766	3246
(731)	(74.54)	(38.27)	(4650)	(5890)	(6560)	(7260)	(8010)	(8790)	(10460)	(12280)
108	249.16	126.73	1241	1571	1749	1939	2137	2346	2792	3277
(745)	(75.94)	(38.63)	(4690)	(5940)	(6620)	(7330)	(8080)	(8870)	(10560)	(12390)

Pitot Pressure psi <sup>a</sup> (kPa)	Ft <sup>b</sup> (m)	Velocity Discharge ft/sec (m/sec)	Orifice Diameter							
			2	2 <sup>1</sup> / <sub>4</sub>	2 <sup>3</sup> / <sub>8</sub>	2 <sup>1</sup> / <sub>2</sub>	2 <sup>5</sup> / <sub>8</sub>	2 <sup>3</sup> / <sub>4</sub>	3	3 <sup>1</sup> / <sub>4</sub>
			(51)	(57)	(60)	(64)	(67)	(70)	(76)	(83)
110	253.77	127.89	1253	1586	1765	1957	2156	2368	2818	3307
(758)	(77.35)	(38.98)	(4640)	(6000)	(6680)	(7400)	(8160)	(8960)	(10660)	(12510)
112	258.38	129.05	1264	1600	1781	1974	2176	2389	2843	3337
(772)	(78.76)	(39.33)	(4780)	(6050)	(6740)	(7470)	(8230)	(9040)	(10750)	(12620)
114	263.00	130.20	1275	1614	1797	1992	2195	2410	2869	3367
(786)	(80.16)	(39.68)	(4820)	(6100)	(6800)	(7530)	(8310)	(9120)	(10850)	(12730)
116	267.61	131.33	1286	1628	1812	2009	2214	2431	2894	3396
(800)	(81.57)	(40.03)	(4860)	(6160)	(6860)	(7600)	(8380)	(9200)	(10940)	(12840)
118	272.23	132.46	1297	1642	1828	2027	2233	2452	2918	3425
(813)	(82.97)	(40.37)	(4910)	(6210)	(6920)	(7660)	(8450)	(9280)	(11040)	(12950)
120	276.84	133.57	1308	1656	1843	2044	2252	2473	2943	3454
(827)	(84.38)	(40.71)	(4950)	(6260)	(6970)	(7730)	(8520)	(9350)	(11130)	(13060)
122	281.45	134.69	1319	1670	1859	2061	2271	2494	2967	3483
(841)	(85.79)	(41.05)	(4990)	(6310)	(7030)	(7790)	(8590)	(9430)	(11220)	(13170)
124	286.07	135.79	1330	1684	1874	2077	2289	2514	2992	3511
(855)	(87.19)	(41.39)	(5030)	(6370)	(7090)	(7860)	(8660)	(9510)	(11320)	(13280)
126	290.68	136.88	1341	1697	1889	2094	2308	2534	3016	3539
(869)	(88.60)	(41.72)	(5070)	(6420)	(7150)	(7920)	(8730)	(9580)	(11410)	(13390)
128	295.30	137.96	1351	1711	1904	2111	2326	2554	3040	3567
(882)	(90.01)	(42.05)	(5110)	(6470)	(7200)	(7980)	(8800)	(9660)	(11500)	(13490)
130	299.91	139.03	1362	1724	1919	2127	2344	2574	3063	3595
(896)	(91.41)	(42.38)	(5150)	(6520)	(7260)	(8040)	(8870)	(9740)	(11590)	(13600)
132	304.52	140.10	1372	1736	1933	2144	2362	2594	3087	3623
(910)	(92.82)	(42.70)	(5190)	(6570)	(7320)	(8110)	(8940)	(9810)	(11670)	(13700)
134	309.14	141.16	1382	1749	1948	2160	2380	2613	3110	3650
(924)	(94.23)	(43.03)	(5230)	(6620)	(7370)	(8170)	(9010)	(9880)	(11760)	(13800)
136	313.75	142.21	1392	1762	1962	2176	2398	2633	3133	3677
(938)	(95.63)	(43.35)	(5270)	(6670)	(7430)	(8230)	(9070)	(9960)	(11850)	(13910)

\* 1 psi — 2.307 ft of water, 1 kPa — 0.102 m of water. For pressure in bar, multiply by 0.01.

<sup>a</sup>This corresponds to velocity head.

<sup>b</sup>This table is computed from the formula:

$$Q = 29.83 c d^2 \sqrt{P} \quad (Q_m = 0.06666 c d^2 \sqrt{P_m}) \quad \text{with } c = 1.00$$

The theoretical discharge of sea water, as from a fire-boat nozzle, is found by subtracting 1 percent from the figures in Table B-8.2, or

$$Q = 29.83 c d^2 \sqrt{P} \quad (Q_m = 0.065 c d^2 \sqrt{P_m})$$

Appropriate coefficient should be applied where it is read from hydrant outlet. Where more accurate results are required, a coefficient be selected and applied to the figures of the table. The discharge from circular openings of sizes other than those in the table can read that quantity discharged under a given head varies as the square of the diameter of the opening.

**Table B-8.2 Values of  $h^{0.54}$**

$h$	$h^{0.54}$	$h$	$h^{0.54}$	$h$	$h^{0.54}$	$h$	$h^{0.54}$
1	1.00	36	6.93	71	9.99	106	12.41
2	1.45	37	7.03	72	10.07	107	12.47
3	1.81	38	7.13	73	10.14	108	12.53
4	2.11	39	7.23	74	10.22	109	12.60
5	2.39	40	7.33	75	10.29	110	12.66
6	2.63	41	7.43	76	10.37	111	12.72

<i>h</i>	<i>h</i> <sup>0.54</sup>	<i>h</i>	<i>h</i> <sup>0.54</sup>	<i>h</i>	<i>h</i> <sup>0.54</sup>	<i>h</i>	<i>h</i> <sup>0.54</sup>
7	2.86	42	7.53	77	10.44	112	12.78
8	3.07	43	7.62	78	10.51	113	12.84
9	3.28	44	7.72	79	10.59	114	12.90
10	3.47	45	7.81	80	10.66	115	12.96
11	3.65	46	7.91	81	10.73	116	13.03
12	3.83	47	8.00	82	10.80	117	13.09
13	4.00	48	8.09	83	10.87	118	13.15
14	4.16	49	8.18	84	10.94	119	13.21
15	4.32	50	8.27	85	11.01	120	13.27
16	4.48	51	8.36	86	11.08	121	13.33
17	4.62	52	8.44	87	11.15	122	13.39
18	4.76	53	8.53	88	11.22	123	13.44
19	4.90	54	8.62	89	11.29	124	13.50
20	5.04	55	8.71	90	11.36	125	13.56
21	5.18	56	8.79	91	11.43	126	13.62
22	5.31	57	8.88	92	11.49	127	13.68
23	5.44	58	8.96	93	11.56	128	13.74
24	5.56	59	9.04	94	11.63	129	13.80
25	5.69	60	9.12	95	11.69	130	13.85
26	5.81	61	9.21	96	11.76	131	13.91
27	5.93	62	9.29	97	11.83	132	13.97
28	6.05	63	9.37	98	11.89	133	14.02
29	6.16	64	9.45	99	11.96	134	14.08
30	6.28	65	9.53	100	12.02	135	14.14
31	6.39	66	9.61	101	12.09	136	14.19
32	6.50	67	9.69	102	12.15	137	14.25
33	6.61	68	9.76	103	12.22	138	14.31
34	6.71	69	9.84	104	12.28	139	14.36
35	6.82	70	9.92	105	12.34	140	14.42

**Figure B-9 Sample hydrant flow test report.**

Hydrant Flow Test Report

Location \_\_\_\_\_ Date \_\_\_\_\_

Test made by \_\_\_\_\_ Time \_\_\_\_\_ .M.

Representative of \_\_\_\_\_

Witness \_\_\_\_\_

State purpose of test \_\_\_\_\_

\_\_\_\_\_

Consumption rate during test \_\_\_\_\_

If pumps affect test, indicate pumps operating \_\_\_\_\_

Flow hydrants: \_\_\_\_\_ A<sub>1</sub> A<sub>2</sub> A<sub>3</sub> A<sub>4</sub> \_\_\_\_\_

Size nozzle \_\_\_\_\_

Pitot reading \_\_\_\_\_

Discharge coefficient \_\_\_\_\_ Total gpm \_\_\_\_\_

gpm \_\_\_\_\_

Static B \_\_\_\_\_ psi Residual B \_\_\_\_\_ psi

Projected results @20 psi Residual \_\_\_\_\_ gpm; or @ \_\_\_\_\_ psi Residual \_\_\_\_\_ gpm

Remarks: \_\_\_\_\_

\_\_\_\_\_

\_\_\_\_\_

\_\_\_\_\_

Location map: Show line sizes and distance to next cross connected line. Show valves and hydrant branch size. Indicate north. Show flowing hydrants - Label A<sub>1</sub>, A<sub>2</sub>, A<sub>3</sub>, A<sub>4</sub>. Show location of static and residual - Label B.

Indicate B Hydrant \_\_\_\_\_ Sprinkler \_\_\_\_\_ Other (identify) \_\_\_\_\_

## B-10 System Corrections.

Flow test results show the strength of the distribution system and do not necessarily indicate the degree of adequacy of the entire water works system. Consider a system supplied by pumps at one location and having no elevated storage. If the pressure at the pump station drops during the test, it is an indication that the distribution system is capable of delivering more than the pumps can deliver at their normal operating pressure. It is necessary to use a value for the drop in pressure for the test that is equal to the actual drop obtained in the field during the test, minus the drop in discharge pressure at the pumping station. If sufficient pumping capacity is available at the station and the discharge pressure could be maintained by operating additional pumps, the water system as a whole could deliver the computed quantity. If, however, additional pumping units are not available, the distribution system would be capable of delivering the computed quantity, but the water system as a whole would be limited by the pumping capacity. The portion of the pressure drop for which a correction can be made for tests on systems with storage is generally estimated upon the basis of a study of all the tests made and the pressure drops observed on the recording gauge at the station for each. The corrections can vary from very substantial portions of the observed pressure drops for tests near the pumping station, to zero for tests remote from the station.

It is preferable to flow water past the residual hydrant.

## Appendix C Referenced Publications

### C-1

The following documents or portions thereof are referenced within this standard for informational purposes only and are thus not considered part of the requirements of this standard unless also listed in Chapter 11. The edition indicated here for each reference is the current edition as of the date of the NFPA issuance of this standard.

#### C-1.1 NFPA Publications.

National Fire Protection Association, 1 Batterymarch Park, P.O. Box 9101, Quincy, MA 02269-9101.

NFPA 13, *Standard for the Installation of Sprinkler Systems*, 1999 edition.

Copyright NFPA

NFPA 13E, *Guide for Fire Department Operations in Properties Protected by Sprinkler and Standpipe Systems*, 2000 edition.

NFPA 20, *Standard for the Installation of Stationary Pumps for Fire Protection*, 1999 edition.

NFPA 22, *Standard for Water Tanks for Private Fire Protection*, 1998 edition.

NFPA 24, *Standard for the Installation of Private Fire Service Mains and Their Appurtenances*, 1995 edition.

NFPA 25, *Standard for the Inspection, Testing, and Maintenance of Water-Based Fire Protection Systems*, 1998 edition.

NFPA 101<sup>®</sup>, *Life Safety Code*<sup>®</sup>, 2000 edition.

NFPA 1901, *Standard for Automotive Fire Apparatus*, 1999 edition.

NFPA 1962, *Standard for the Care, Use, and Service Testing of Fire Hose Including Couplings and Nozzles*, 1998 edition.

NFPA 1964, *Standard for Spray Nozzles (Shutoff and Tip)*, 1998 edition.